

# Cuisinart®

INSTRUCTION AND  
RECIPE BOOKLET



**SMARTPOWER PREMIER DUET™ 600-WATT BLENDER/FOOD PROCESSOR**

**CBT-500FP**

For your safety and continued enjoyment of this product, always read the instruction book carefully before using.

---

# IMPORTANT SAFEGUARDS

When using an electrical appliance, basic safety precautions should always be followed, including the following:

1. **READ ALL INSTRUCTIONS BEFORE USING.**
2. To protect against the risk of electrical shock, do not put motor base of blender in water or other liquid.
3. Close supervision is necessary when any appliance is used by or near children.
4. Unplug from outlet when not in use, before putting on or taking off parts, and before cleaning or removing contents from blender jar. **Never put hands into the blender jar or container, or handle the blades with appliance plugged in.**
5. Avoid contact with moving parts.
6. Do not operate any appliance with a damaged cord or plug or after the appliance malfunctions, or is dropped or damaged in any manner. Return appliance to nearest Cuisinart service facility for examination, repair, and/or mechanical or electrical adjustment.
7. The use of attachments, including canning or ordinary jars, not recommended or sold by Cuisinart may cause fire, electrical shock, or risk of injury to persons.
8. Do not use outdoors.
9. Do not let cord hang over edge of counter or table or touch hot surfaces.
10. **Keep hands and utensils out of jar while blending, to reduce the risk of severe injury to persons or damage to blender itself.** A rubber or plastic spatula may be used but must be used only when the blender is turned Off.
11. When blender is in On mode, and LED lights are flashing, do not touch cutting assembly, interfere with blade movement, or remove blender jar cover. Accidentally touching a speed button may activate the blender.
12. **BLADES ARE SHARP. HANDLE CAREFULLY.**
13. To reduce the risk of injury, never place cutting assembly on base unless the blender jar is properly attached.
14. Always operate blender with the cover in place.
15. Never leave your blender unattended while it is running.
16. When blending HOT liquids, remove measured pour lid (center piece of cover) to allow steam to escape.
17. Twist on locking ring firmly. Injury can result if moving blades accidentally become exposed.
18. Do not use an extension cord with this unit. Doing so may result in fire, electrical shock, or personal injury.  
**Regarding your cord set:** A longer cord has been provided so that you will have flexibility in positioning your Cuisinart® SmartPower Premier Duet™ 600-Watt Blender/Food Processor near an electrical outlet. Exercise care when using the longer cord, to avoid entangling or tripping over the cord. The longer cord should be arranged so that it will not drape over the counter or tabletop, where it can be pulled on by children or tripped over. Excess cord should be stored in the cord storage area at the back of the blender base to avoid injury caused by the longer cord.
19. Wash the blender jar, cutting assembly, locking ring, and cover before first use.
20. **WARNING: TO REDUCE THE RISK OF ELECTRICAL SHOCK OR FIRE, DO NOT REMOVE THE BASE PANEL. NO USER-SERVICEABLE PARTS ARE INSIDE. REPAIR SHOULD BE DONE ONLY BY AUTHORIZED PERSONNEL.**
21. **WARNING: FLASHING LIGHT INDICATES READY TO OPERATE. DO NOT TOUCH BLADES**
22. The use of attachments, including canning jars, not recommended by the manufacturer may cause a risk of injury to persons.
23. Keep hands and utensils away from moving blades or discs while processing food to reduce the risk of severe injury to persons or damage to the food processor. A scraper may be used but must be used only when the food processor is not running.
24. To reduce the risk of injury, never place cutting blade or discs on base without first putting bowl properly in place
25. Be certain cover is securely locked in place before operating appliance
26. Never feed food by hand. Always use food pusher
27. Do not attempt to defeat the cover interlock mechanism

---

# SAVE THESE INSTRUCTIONS FOR HOUSEHOLD USE ONLY

## NOTICE

This appliance is of the grounded type; the extension cord should be a grounded type 3-wire cord. If the plug does not fit, contact a qualified electrician. Do not modify the plug in any way.

## UNPACKING INSTRUCTIONS

1. Place the gift box containing your Cuisinart® SmartPower Premier Duet™ 600-Watt Blender/Food processor on a flat, sturdy surface before unpacking.
2. Remove instruction booklet and other printed materials from top of corrugated insert.
3. Next, remove the top corrugated insert. It contains the adapter stem, and the slicing/shredding disc. Carefully remove slicing/shredding disc, as it is very sharp, then remove lid and adapter stem.
4. Remove the top corrugated insert containing the blender jar assembly. Be careful not to tip the jar when removing.
5. Remove the middle corrugated insert containing the fill cap.
6. Carefully lift blender base from box and set aside.
7. Remove food processor accessory and any additional literature from the box.

To assemble the blender, follow the Assembly instructions on page 4 of this instruction booklet. Replace all corrugated inserts in the box and save the box for repackaging. See the Features and Benefits section on page 4 for a listing of all blender parts.

**Before using for the first time:** Wash all parts according to the Cleaning and Maintenance section on page 7 of this booklet to remove any dust or residue.

## INTRODUCTION

You'll be amazed at what this combination blender/food processor can do! The SmartPower Premier Duet™ is our most powerful blender and a full-featured 3-cup Cuisinart® Food Processor – in one! It lets you effortlessly blend smoothies, mix batter, crush ice, purée soup, chop nuts, slice potatoes, or shred cheese...all with easy push-button controls. Get ready to have more fun and get more creative in your own kitchen, with Cuisinart!

## TABLE OF CONTENTS

Important Safeguards .....	Page 2
Unpacking Instructions .....	Page 3
Introduction .....	Page 3
Blender Features and Benefits .....	Page 4
Blender – Getting Started .....	Page 4
Assembly .....	Page 4
Helpful Reminders .....	Page 5
Operation .....	Page 5
Quick Reference Guides .....	Page 5
Cleaning and Maintenance .....	Page 7
Do's and Don'ts .....	Page 7
Food Processor Features and Benefits .....	Page 8
Food Processor – Getting Started .....	Page 9
Assembly .....	Page 9
Operating Controls .....	Page 9
Chopping, Puréeing and Mixing .....	Page 10
Slicing and Shredding .....	Page 11
Quick Reference Guides .....	Page 11, 13
Recipe Tips .....	Page 12
Cleaning and Storing .....	Page 14
Warranty Information .....	Page 14
Recipes .....	Page 15

# BLENDER FEATURES AND BENEFITS

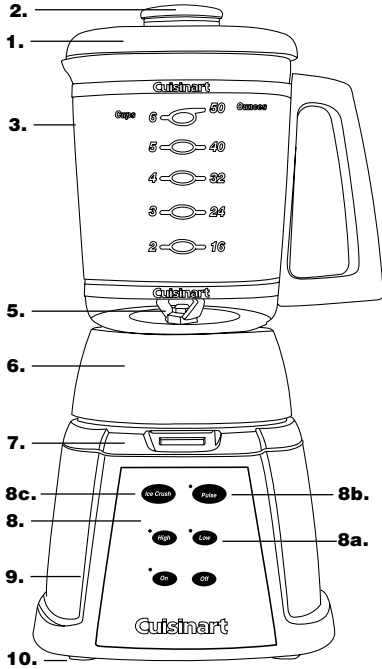

**Note: Blades are sharp... handle carefully.**

## 6. Locking Ring

Is self-aligning so that the glass blender jar slides easily into position.

## 7. Count-Up™ Timer

Five-minute timer times your recipes for perfect results.

## 8. Push-button Controls

### a. High and Low Buttons

Choose High or Low speed to blend the ingredients to the desired consistency. Red LED lights will indicate which speed you are using.

### b. Pulse Button

Allows you to pulse at High or Low speeds, so you can

## 1. Cover

Just press on. Tightfitting seal resists leakage.

## 2. Measured Pour Lid

Allows you to measure and add ingredients without removing the cover.

## 3. 50-oz. Glass Jar

Has a unique, sturdy, wide-mouth design.

## 4. Leak-proof Rubber Gasket (not shown)

Holds the glass jar snugly in position for safe operation.

## 5. High-quality Cutting Assembly with Patented Stainless Steel Blades

Is strong enough for all blender tasks, including tough jobs, from ice crushing to chopping delicate herbs.

blend ingredients only as much as needed.

## c. Ice Crush Button

Press to begin crushing. This button is preset to the best speed for crushing ice.

## 9. Heavy-duty Motor Base

Is so sturdy and stable, it will not “walk” on your counter – even during ice crushing! Used for both the blender jar and the the food processor bowl.

## 10. Slip-proof Feet

Prevent movement during use and prevent damaging marks on countertops or tables.

## 11. Cord Storage (not shown)

Keeps countertop safe and neat by conveniently storing excess cord.

# BLENDER GETTING STARTED STEP BY STEP

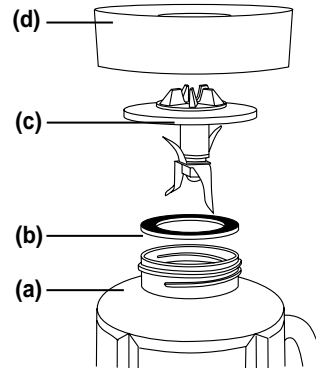

## ASSEMBLY

To use your Cuisinart® SmartPower Premier Duet™ 600-Watt Blender/Food Processor begin by assembling the blender jar.

1. Turn the blender jar (a) upside down, and place it flat on a sturdy surface.
2. Position the rubber gasket (b) on the round opening on the bottom of the blender jar.
3. Turn the cutting assembly (c) upside down, and place the blade end in the blender jar opening.

**Note: Blades are sharp... handle carefully.**

4. Secure the rubber gasket and cutting assembly in position by placing the smaller opening of the locking ring (d) on top of the cutting assembly. Engage threads by twisting the locking ring clockwise until tightened. Make sure locking ring is tightly fastened to blender jar. Once assembled, turn the blender jar right-side up.

5. Push the cover onto the top of the blender jar. Push the measured pour lid into the cover.
6. Place the blender jar on the motor base so that the jar markings are facing you and the handle is positioned to one side.
7. Plug in power cord. Your blender is now ready to be used.

## HELPFUL REMINDERS

- Once the cover is in position, additional ingredients can be added during blending by simply lifting the measured pour lid, adding ingredients, and replacing the measured pour lid.
- Cover should always be in place while the unit is on.
- **Warning:** Do not place blender jar onto base while motor is running.
- Do not twist locking ring from blender jar when removing blender jar from base. Simply lift blender jar from motor base.
- Boiling liquid or solid frozen foods (with the exception of ice cubes or ½ inch [1.3 cm] pieces of frozen fruit) should never be placed in the blender jar.
- Do not place ice, frozen foods or very cold liquids into a blender jar which has come directly from a hot dishwasher.
- Do not place very hot liquids or foods into a blender jar which has come directly from the freezer. Boiling liquids should cool for 5 minutes before being placed in blender jar.
- Follow Cleaning and Maintenance instructions on page 7, prior to your first use.

## OPERATION

1. Place the motor base of your Cuisinart® SmartPower Premier Duet™ 600-Watt Blender/Food Processor onto a flat, sturdy surface. It is important that the surface be clean and dry. Assemble the blender by following the assembly instructions. Once the jar is assembled and is in position on the motor base, plug the Cuisinart® SmartPower Premier Duet™ 600-Watt Blender/Food Processor into an electrical outlet.
2. Add all necessary ingredients to the blender jar, and replace the cover. You may add more ingredients by lifting the measured pour lid and dropping ingredients through the fill area. Replace the measured pour lid after adding ingredients. **Do not place hands into blender jar with blender plugged in.**

## QUICK REFERENCE GUIDE – BLENDER

To Activate Blender	Press On - The blender is in ON mode.
To Begin Blending	Press desired speed button.
To Change Speeds	Press desired speed button.
To Pulse	In On mode press Pulse, then press and release desired speed button as needed.
To Crush Ice	In On mode, press and release Ice Crush button as needed.
To Stop Blending (and Deactivate Blender)	Press Off button.
To Stop Blending (in High or Low Speeds and Pause Timer)	Press High or Low button.
To Stop Blending (in Pulse or Ice Crush Mode)	Release button.

## SPEED SELECTION GUIDE

Refer to this guide to choose the best blender speed for your desired result.

Ingredient/Recipe	Speed	Result
Reconstituting frozen juice concentrate	Low	Smooth and full-bodied
Mayonnaise	Low	Thick and creamy
Salad dressings	Low or High	Completely blended and emulsified
Nuts (shelled, 1/2 cup or less at a time)	Low Pulse to chop	Coarse to fine
Heavy or whipping cream	Low - pulse	Thick creamy topping
Bread, cookies or crackers (add 1/2" pieces, 1 cup or less at a time)	Low - pulse, then blend	Coarse to fine as desired
Grating/chopping citrus zest (add 1-2 tsp. sugar or salt from recipe)	Low - pulse/blend	Uniformly fine
Smoothies, shakes, health drinks	High	Smooth, creamy and thick
Baby food/fruit and vegetable purée	High	Smooth and creamy
Frozen cocktails	High	Thick and slushy
Hard cheeses	Low-pulse, then blend	Coarse to fine
Spices	Low or high pulse, then blend	Coarse to fine
Ice	Ice Crush, pulse or continuous	Coarse crush to snowy

**Note:** Add liquid ingredients first, then follow with solid ingredients. This will provide more consistent blending and prevent unnecessary stress on the motor.

**Note:** To remove blender jar cover, lift edge of cover upward. Lifting measured pour lid will not remove cover.

- 3. TIMING YOUR RECIPES:** The SmartPower Premier Duet™ 600-Watt Blender/Food Processor features a 5-minute Count-Up™ Timer, so that you can time your recipes and guarantee perfect results. The timer begins counting from 0 as soon as you push your desired speed: High, Low, Pulse or Ice Crush. The timer will continue to count up even if you change speeds during blending. You can pause the timer by pausing the blending process. Do this by pushing the button corresponding to the speed at which you are currently blending. For example: If you are blending in Low speed and you push the Low speed button, the blender will stop blending and the timer will stop counting, but the unit will remain on. To continue blending and timing your recipe, push one of the speed buttons. The timer will also stop counting when it reaches 5:00 minutes. The timer will reset itself only when the Off button is pushed.
- 4. START BLENDING:** Press the On button. The red LED indicator light will illuminate, indicating that the blender is turned on but no speed has been selected.

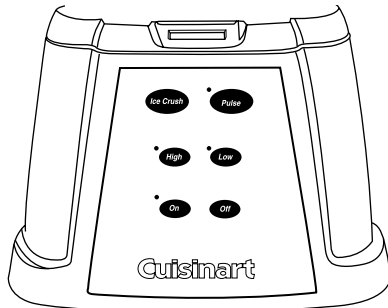

- 5. CHOOSE BLENDING SPEED:** Press High or Low button to determine the speed at which you would like to blend the ingredients. Both the On indicator light and the activated speed indicator light will glow. The blender will now be functioning at the desired speed. It is possible to switch speeds without pressing the Off button, by simply pushing the other speed button.

**WARNING:** FLASHING LIGHT INDICATES READY TO OPERATE. DO NOT TOUCH BLADES

**Note:** The Count-Up™ timer will begin counting when the desired speed button is pushed. The timer will continue to count if you change speeds.

**6. TO PAUSE OR STOP BLENDING PROCESS:**

**a. To Pause Blending Process:**

Push the button corresponding to the speed at which you are currently blending. For example: If you are blending on High speed, push the High speed button and the blender will stop blending, but the unit will remain on.

**Note:** By pausing the blending process, you will also pause the timer. The timer will pause until you start blending again.

**b. To Stop Blending Process:**

Push the Off button when you are finished with your recipe and would like to turn the blender off.

**Note:** When you push the Off button, the timer will stop counting and the LED display will reset to 0:00. When the blender is turned back on and a speed button is pushed, the timer will begin to count from 0:00.

- 7. PULSE MODE:** The pulse mode allows you to create a burst of power for quick, efficient blending. To use the pulse function, push the On button and the red LED indicator light will illuminate. Push the Pulse button, and the pulse LED indicator light will blink. Push and release the desired speed button. Repeat as desired. You determine the duration of each pulse. While pulsing, the LED indicator light will glow. The pulse function can be used to break apart larger pieces of food or to control the texture of food when chopping. The pulse function is also effective in starting the blending process when you do not want continuous power, or when processing items that do not require an extended amount of blending.

**Note:** The timer will count when you push or hold down the Pulse button. The timer will pause when you release the Pulse button.

- 8. TO CRUSH ICE:** The SmartPower Premier Duet™ 600-Watt Blender/Food Processor motor is strong enough to crush ice without liquid at any speed; however for your convenience, we have preset the best speed for ice crushing. To give you greater control, the ice crush function automatically operates as

---

a pulse function. To crush ice, place ice cubes in the blender jar. Press the On button. The On indicator light will illuminate. Press the Ice Crush button in short pulses until ice is crushed to desired consistency. See Recipe Tips section on page 12 for more details.

**Note:** The timer will count when you push or hold down the Ice Crush button. The timer will pause when you release the Ice Crush button.

9. **TO DISLodge FOOD:** Use a rubber or plastic spatula to help remove food lodged around the cutting assembly. **DO NOT USE SPATULA UNTIL YOU HAVE TURNED THE BLENDER OFF.** Replace the cover and measured pour lid and continue blending, if necessary. Make sure spatula is not inside the blender jar before blending.
10. **WHEN FINISHED BLENDING:** Press the Off button and unplug the blender from the electrical outlet. Never remove the blender jar from the motor base until the blender is off. Do not twist locking ring from blender jar when removing jar from motor base. Simply lift blender jar from motor base. **Do not place hands into blender jar with blender plugged in.**

## CLEANING AND MAINTENANCE

Always unplug your Cuisinart® SmartPower Premier Duet™ 600-Watt Blender/Food Processor from the electrical outlet before cleaning. The blender is made of corrosion-resistant parts which are easy to clean. Before first use and after every use, clean each part thoroughly. Periodically check all parts before reassembly. If any part is damaged or blender jar is chipped or cracked, **DO NOT USE BLENDER.**

Remove the blender jar from the motor base by lifting straight up and away. Twist off the locking ring by turning counterclockwise.

Remove the cutting assembly and rubber gasket. Wash in warm soapy water, rinse, and dry thoroughly.

Place the locking ring in the upper rack of the dishwasher or wash in warm water.

**CAUTION:** Handle the cutting assembly carefully. It is **SHARP** and may cause injury. Do not attempt to remove blades from cutting assembly.

Remove the blender jar cover and the measured pour lid. Wash in warm, soapy water; rinse and dry thoroughly, or place in upper rack

of dishwasher. The blender jar must be washed in warm, soapy water and rinsed and dried thoroughly. The blender jar can also be placed upside down in dishwasher.

Finally, wipe the motor base clean with a damp cloth to remove any residue, and dry thoroughly. Never submerge the motor base in water or other liquid, or place in a dishwasher.

**Tip:** You may wish to clean your blender cutting assembly as follows: Squirt a small amount of dishwashing liquid into assembled blender jar and fill halfway with warm water. Run on LOW for 15 seconds. Repeat, using clean tap water. Empty blender jar and carefully disassemble parts. Wash cutting assembly, gasket and locking ring in warm, soapy water. Rinse and dry all parts thoroughly.

## DOS AND DON'TS WHEN USING THE BLENDER

### DO

- Make sure the electrical outlet is rated at the same voltage as that stated on the bottom of the blender motor base.
- Always use the blender on a clean, sturdy and dry surface.
- **Always add liquid ingredients to the blender jar first, then add remaining ingredients. This will ensure that ingredients are uniformly mixed.**
- Cut most foods into cubes approximately ½ inch (1.3 cm) to 1 inch (2.5 cm) to achieve a more uniform result. Cut all cheeses into pieces no larger than ½ inch (1.3 cm).
- Use the measured pour lid to measure liquid ingredients such as juice or alcohol. Replace measured pour lid after ingredients have been added.
- Use a rubber or plastic spatula as needed, only when the blender is turned off. Never use metal utensils, as damage may occur to the blender jar or cutting assembly.
- Place cover on firmly. Always operate the blender with the cover on.
- Make sure locking ring is tightly attached to blender jar.
- Always remove locking ring, cutting assembly, and rubber gasket before cleaning.
- When scraping the blender jar with a spatula, remove the food from the sides of the blender jar and place food in the center of the blender jar, over the cutting assembly.

- When chopping fresh herbs, garlic, onion, zest, bread crumbs, nuts, spices, etc, make sure the blender jar and cutting assembly are completely dry.
- If food tends to stick to the sides of the blender jar when blending, pulse in short bursts.
- Pulses should be short bursts. Space the pulses so the blades stop rotating between pulses.

#### DON'T

- Don't store food or liquids in your blender jar.
- Don't place cutting assembly and locking ring onto motor base without the blender jar attached.
- Do not attempt to mash potatoes, knead heavy dough, or beat egg whites. These can be done in the food processor.
- Don't remove blender jar while unit is on. Keep the blender jar cover on the blender jar while blending.
- Don't twist locking ring from blender jar when removing blender jar from motor base. Simply lift blender jar from motor base.
- Don't overprocess foods. Blender will achieve most desired results in seconds, not minutes.
- Don't overload blender. If the motor stalls, turn the blender off immediately, unplug the unit, and remove a portion of the food, then continue.
- Don't use any utensil inside the blender jar while the motor is on.
- Don't use any container or accessories not recommended by Cuisinart. Doing so may result in injury.
- Don't place hands inside the blender jar when blender is plugged in.
- Don't add boiling liquids or frozen foods (except ice cubes or 1/2 inch pieces of frozen fruit) to glass blender jar. Boiling liquids should cool for 5 minutes before being placed in blender jar.

## FOOD PROCESSOR FEATURES

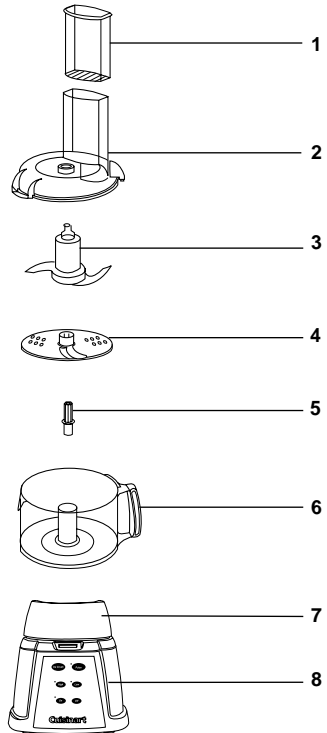
1. **Food pusher with oil dispenser**
  2. **Work bowl cover with feed tube**
  3. **Stainless steel chopping blade**
  4. **Stainless steel reversible slicing/shredding disc**
  5. **Adapter stem**
  6. **Clear work bowl**
  7. **Gearbox collar**
  8. **Motor base**  
Used for both the blender jar and the food processor bowl
- 
- The diagram illustrates the various components of a Cuisinart food processor. It shows a vertical stack of parts: a food pusher with an oil dispenser (1), a work bowl cover with a feed tube (2), a stainless steel chopping blade (3), and a stainless steel reversible slicing/shredding disc (4). Below these are an adapter stem (5), a clear work bowl (6), and a gearbox collar (7). At the bottom is the motor base (8), which is used for both the blender jar and the food processor bowl. The Cuisinart logo is visible on the motor base.



---

# FOOD PROCESSOR

## GETTING STARTED STEP BY STEP

Please note that the bowl with collar will fit on the base in eight different positions. The handle can be in front or on either side and the feed tube in front, back, or on either side. Directions for use reference a certain position for instructional purposes only.

### FOOD PROCESSOR ASSEMBLY

#### CHOPPING, PURÉEING AND MIXING

1. Hold gearbox collar in one hand and work bowl handle in the other. Twist bowl clockwise onto collar.
2. Place collar with bowl onto motor base with handle facing front.
3. Place chopping blade over shaft in work bowl. Chopping blade should slide easily to the bottom of the bowl. Lower blade will almost touch bottom of bowl.

#### **BE SURE TO HANDLE THE METAL BLADE WITH CARE AS IT IS RAZOR SHARP!**

4. Place food to be processed in work bowl. Put cover on work bowl, with feed tube at about 11 o'clock. Turn the cover clockwise until it fits into position. Cover lock must click into locked position prior to use. If you have trouble fitting the cover on the work bowl, turn chopping blade hub slightly and replace cover.
5. The food pusher fits in feed tube with more rounded side toward the outside of the bowl. **ALWAYS USE PUSHER TO GUIDE FOOD THROUGH FEED TUBE. NEVER USE YOUR FINGERS OR SPATULA.**
6. Plug your SmartPower Premier Duet™ 600-Watt Blender/Food Processor into a wall outlet. Push the On button and then the High button to start chopping or puréeing. It is recommended that one hand be placed on the food processor lid while in use, to provide unit stability. If the machine doesn't start, make sure it is plugged in and the work bowl and cover are locked into place. The food processor will not start until the collar, work bowl and work bowl lid are locked into place. Nevertheless, always unplug the unit before placing hands into the food processor bowl.

**NOTE:** The motor base will start, but the food processor blade will not turn until assembled properly.

The reversible slicing/shredding disc can slice and shred a variety of fruits and vegetables, meats and cheeses. See Quick Reference guide for Preparing Foods for Slicing and Shredding, page 13.

### FOOD PROCESSOR ASSEMBLY

#### SLICING AND SHREDDING

1. Hold collar in one hand and bowl handle in the other. Twist bowl clockwise onto collar.
2. Place collar with bowl onto motor base with handle facing front.
3. Place adapter stem onto the center shaft. **To slice:** Attach disc to stem with the raised edge of slicer on top. **To shred:** Attach disc to stem with the raised shredding slots on top. Place the slicing/shredding disc onto shaft with the desired cutting blade facing up. Be sure to handle the metal blade with care, as it is razor sharp.
4. Place cover on work bowl, with feed tube at about 11 o'clock. Turn cover clockwise until it fits into position. Insert food in feed tube.
5. Hold pusher with more rounded side toward the outside of the bowl and insert it in feed tube over food. Always use pusher to guide food through feed tube. Never use your fingers or spatula.
6. Plug your Cuisinart® SmartPower Premier Duet™ 600-Watt Blender/Food Processor into a household electrical outlet.
7. To remove cover, unlock it by turning it counterclockwise, then lift it straight up.

#### OPERATING CONTROLS

Your SmartPower Premier Duet™ appliance uses the high speed with the Food Processor attachment. This button is the perfect speed for all your food processing tasks. Always use this speed when using the food processor. You may also use the Pulse button set on High with this function for pulse-chopping.

To use your food processor, make sure that the bowl is assembled properly and the blade or slicing/shredding disc and the cover are locked into place.

When you use the control panel, the LED will light next to each button you press.

Press the On button. For continuous operation, press the High button. Motor will start if you have followed assembly instructions. To turn motor off, press the High button again or the Off button.

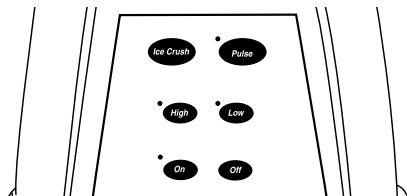

For on-off operation, called pulse-chopping or pulsing, press the On button, press the Pulse button, and then press and release the High button the desired number of times. Motor runs as long as you hold the High button down. The motor stops when you release control switch. Try it a few times.

You control the duration and frequency of pulses by the length of time you hold the High button down and the rate at which you press it. Allow enough time between pulses to let food in work bowl fall to bottom.

Always use the High button for pulse/chopping. Never turn cover back and forth to start and stop processor.

## CHOPPING, PURÉEING AND MIXING

Refer to Food Processor Assembly instructions on page 9.

1. Remove cover and put food into work bowl. First, cut food into  $\frac{3}{4}$ " pieces. You will get a more even chop if you start with pieces that are all the same size. Put pieces into work bowl with metal blade in place. You can put in up to 1 cup of food at a time. If you want to process more, do it in batches.
2. Put on cover and lock it. Insert pusher. It is recommended that one hand be placed on the food processor lid while in use, to provide unit stability. Press the On button, press the Pulse button, and the High button (to pulse), then release. Repeat two to three times. Each time blade stops, let food pieces drop to the bottom of bowl before pulsing again. This ensures that the blade will chop them at every pulse. Watch what happens to the food. With pulse/chopping technique, you can get an even chop without danger of overprocessing. Check texture by looking through work bowl. Be careful not to overprocess. For a coarse chop, pulse only a few times.

3. If you want a finer chop or purée, press the On button and then the High button and let machine run continuously until the food is chopped as fine as you want it. Check frequently through clear cover or bowl to avoid chopping too fine. Use a plastic spatula to scrape down any pieces that stick to inside of bowl. Onions and other food with a high water content turn into a smooth purée very quickly. Do not overchop – look at food frequently through work bowl.

To purée, follow same procedure as for chopping, but let machine run until food is a smooth purée.

New users are often surprised at how fast the processor works. You will quickly get used to its great speed.

These are some conditions that affect your results:

- Size of pieces you put in bowl – all should be about the same size.
- Amount of food you process – don't add too much.
- Type of processing you choose – continuous or pulse/chopping.

## ADDING FOOD WHILE PROCESSING

To add liquid while the machine is running, pour it through open feed tube. This is especially useful when making mayonnaise or dressings.

A small hole in the pusher allows you to add liquids in a very slow, steady stream – useful when making sauces.

When you want to add small pieces of food like cheese, meat or garlic cloves while machine is running, drop them through open feed tube.

To prevent spills when adding sugar and other dry ingredients, use a funnel.

## REMOVING PROCESSED FOOD

Before removing processed food, press Off button and wait for blade to stop spinning. Then remove cover by turning it counter-clockwise. Never try to remove cover and work bowl together; this can damage work bowl.

It is important **not** to let metal blade fall out of work bowl as you empty it. Here are two ways to prevent it from falling out:

1. Before tilting bowl, use spatula to remove food from around blade. Carefully remove blade by the plastic hub.

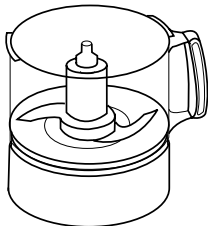

2. Hold top of blade in place with finger or spatula while pouring out processed food.

At this point, you may either lift the work bowl off motor base, or hold the collar at the base and turn the handle of the bowl counterclockwise and lift blade straight up.

Your SmartPower Premier Duet™ 600-Watt Blender/Food Processor makes many everyday food preparation tasks much easier and faster. Follow these guidelines to get best results when using metal blade with food you prepare most often.

**NOTE:** Occasionally, a piece of food may become wedged between the blade and the work bowl. If this happens, remove the cover, lift the blade out carefully and remove the wedged piece. Empty the bowl, reinsert the blade and lock the cover into place. Process smaller amounts of the food at one time.

### SLICING AND SHREDDING

1. Assemble clear work bowl on collar and base in the usual way. (See steps 1 and 2 on page 9.)
2. Pick up adapter stem. Hold stem by side that has the octagon shape (eight-sided) and push rounded side down as far as it will go on motor shaft.
3. Place the reversible slicing/shredding disc with the desired cutting edge facing up onto the adapter stem. Always handle slicing/shredding disc by the rim. Never touch sharp cutting blades.

## QUICK REFERENCE GUIDE – PROCESSING WITH CHOPPING BLADE

### THE FOOD

### HOW TO PREPARE IT

Fruit and vegetables	Peel and core if necessary. Remove large hard pits and seeds. Cut into $\frac{3}{4}$ " pieces and process up to 1 cup at a time.
Meat, poultry and fish	These should be very cold but not frozen. First, cut into $\frac{3}{8}$ " pieces. Put up to $\frac{1}{2}$ pound in work bowl. If you want to chop or purée more, do it in batches of not more than $\frac{1}{2}$ pound each. Pulse/chop or run continuously until desired consistency is reached. Check texture every 2 or 3 seconds to avoid overprocessing.
Bread, crackers or cookies	Break into 1" pieces and process continuously until texture for crumbs is fine. For seasoned crumbs, chop with herbs. For buttered crumbs, dribble melted butter through feed tube while processing – 1 teaspoon melted butter for each slice of bread.
Crumb crusts	Chop crackers or cookies as described in preceding paragraph. Add sugar, spices and butter and cut into pieces, as specified by recipe. Pulse/chop until combined.
Hard cheese grated	If it's too hard to cut with a knife, don't try to chop it – it may damage blade. First cut into $\frac{3}{8}$ " pieces. Pulse/chop until pea-sized, then process continuously. You can chop it as coarse or as fine as you want. Simply run machine longer for finer chop. Process up to 3 ounces at one time.
Whipping cream	Processor-whipped cream works well for most purposes. It is excellent as a topping for desserts or hot drinks. Cream must be at refrigerator temperature. You can whip up to 1 cup at a time.
Parsley and other fresh herbs	Work bowl and metal blade must be clean and dry. Remove stems; use leaves only. Dry herbs completely. The more herbs you chop at once, the finer chop you can get. Chopped herbs keep for several days in the refrigerator in airtight bags, or can be frozen for months.

- 
4. Put cover on work bowl, lock it into place by twisting it clockwise and insert food in feed tube.
  5. Insert pusher. Use moderate pressure to push down on pusher with one hand while using your other hand to push the On button, Pulse button, and hold down the High button. Slicing and shredding take only a few seconds. Wait until disc stops spinning before removing cover. When it stops, remove cover before removing work bowl. Never try to remove cover and work bowl together; this could damage work bowl.
  6. Remove slicing/shredding disc before removing work bowl. To remove it, grasp flat top section of adapter stem and lift it straight up. Holding work bowl collar, turn work bowl counter-clockwise and lift it straight up to remove it from base.

## RECIPE TIPS

You'll find many easy ways to prepare savory, healthful meals with your Cuisinart® SmartPower Premier Duet™ 600-Watt Blender/Food Processor. The simple recipes that follow include some old Cuisinart favorites as well as some creative combinations that are sure to please your friends and family. Thanks to the superior ice crushing power of the SmartPower Premier Duet™ 600-Watt Blender/Food Processor, you'll also be able to make delicious frozen drinks.

## TIPS FOR USING YOUR NEW BLENDER/FOOD PROCESSOR:

### **Chopping Nuts**

Pulse ½ cup of nuts (shells removed) and chop 4-5 times. Turn blender off; scrape blender jar with spatula. Turn blender on and Pulse on chop 2-3 times. Turn blender off. Pulse fewer times for more coarsely chopped results. For best results, process no more than 1 cup at a time.

### **Bread, Cookie or Cracker Crumbs**

For best results, use day-old bread (drier bread works best). Break bread slices into ½" pieces, and process no more than 1 cup of pieces at a time on mix for 5-10 seconds. Crackers and cookies should also be broken into ½" pieces; process 1 cup at a time on mix for 10-15 seconds. Turn blender off.

### **Crushing Ice (Blender Jar Only)**

Add up to 10 large ice cubes to blender jar. Press the Ice Crush button, using short bursts, 10 times or until cubes are the consistency of snow. Turn blender off. Pulse fewer times if coarsely chopped ice is desired.

### **Grating Citrus Zest**

For best results, blender jar and cutting assembly must be clean and dry. Remove zest from fruit in strips (using vegetable peeler). Use no more than 8 strips at a time (zest of one medium lemon). Cut strips in half. Add strips and 1 teaspoon sugar (from recipe) to the blender jar. Blend on food processor speed for 15-20 seconds. Turn blender off.

### **Grinding Hard Cheese**

Cut cheese into ½" pieces. Blend on food processor speed for 30 seconds. Turn blender off. For best results, grind no more than 3 ounces of cheese at a time.

### **Grinding Spices**

For best results, blender jar and cutting assembly must be clean and dry. Add ¼ -½ cup of spices, seeds or peppercorns to blender jar. Blend on food processor speed for 30-35 seconds. Turn blender off.

### **Whipping Cream**

Whip 1 cup of cream (whipping or heavy cream) at a time. Blend on mix, and process for 45-60 seconds or until creamy and smooth. If making sweetened cream, add sugar after 10 seconds. Turn blender off. Makes about 1 cup.

### **Puréeing Sun-Dried Tomatoes**

Rehydrate 1 ounce of tomatoes in 1 cup boiling water. Allow to sit for 10 minutes or until softened. Add tomatoes and water to blender jar. Cover and pulse on food processor speed 5 times; then run continuously on food processor speed for 15-20 seconds. Turn blender off. Drain in fine strainer if desired. Makes about ½ cup of puréed tomatoes.

## QUICK REFERENCE GUIDE – PROCESSING WITH THE SLICING/SHREDDING DISK

Food	To Prepare for Slicing	To Prepare for Shredding
Long narrow foods like carrots, celery, cucumbers, and zucchini	Cut into even lengths about 1" shorter than height of feed tube. Stand pieces upright in feed tube, flat side down, adding enough pieces so they cannot tilt.	For long shreds, cut into largest size that will fit sideways in feed tube. Stack in feed tube to about 1" from top. For shorter shreds, stand pieces upright in feed tube, flat side down (as described in slicing column).
Apples, onions, potatoes, peppers, tomatoes and other large round fruits and vegetables	Cut one end flat then cut lengthwise in halves or quarters. Pack solidly in feed tube to prevent tilting. Fill feed tube to about 1" from top. Use light to moderate pressure.	Prepare same as for slicing. Place in feed tube sideways for longer shreds, or upright for shorter shreds.
Strawberries, mushrooms, radishes and other small, round fruits and vegetables	Slice off top and bottom, leaving center section. Place in feed tube, flat side down.	Radishes shred well. Prepare same as for slicing.
Cabbage, iceberg lettuce	Cut off top and bottom, leaving center section. Cut into wedges to fit feed tube upright. Remove core. Cut top and bottom pieces in similar wedges.	Prepare same as for slicing
Uncooked meat and poultry (8 oz. maximum at one time)	Use boneless cuts. Cut into feed-tube lengths. Remove skin if desired. Wrap in plastic wrap and put in freezer until it feels hard when you try to squeeze it but is still easily pierced through with tip of sharp knife. Remove plastic wrap and stand upright in feed tube. <b>Note:</b> Chicken and beef for stir-fries should be sliced with the grain. Boned, skinned chicken breast will usually fit when frozen as described above and cut in half crosswise.	Prepare same as for slicing.
Soft cheeses like mozzarella	Do not slice.	Chill in freezer for 5 minutes before processing. Cut into pieces to fit feed tube. Stand pieces in feed tube and <b>use light pressure on pusher</b> . Use 4 oz. maximum.
Medium-hard cheeses like Cheddar and Swiss	Cut into pieces to fit feed tube. Stand pieces in feed tube and use light pressure on pusher.	Prepare same as for slicing. Chill 5 minutes in freezer before processing. Use 4 oz. maximum.
Hard cheeses like Parmesan		Do not shred.

---

## CLEANING AND STORING YOUR SMARTPOWER PREMIER DUET™ FOOD PROCESSOR ATTACHMENTS

Store the chopping blade and slicing/shredding disc as you would sharp knives – out of the reach of children.

The work bowl, cover, pusher, chopping blade, and slicing/shredding disc are top-shelf dishwasher safe. When placing parts in your dishwasher, insert the work bowl upside down. Remember where you place the sharp blade and disc, and be certain to unload the dishwasher carefully.

The gearbox collar is not immersible. To clean, just wipe with a damp cloth.

If you wash the blades and discs by hand, do it carefully. Avoid leaving them in soapy water where they may disappear from sight. To clean the metal blade, fill the work bowl with soapy water, hold the blade by its plastic center and move rapidly up and down on the center shaft of the bowl. Use of a spray hose is also effective. If necessary, use a brush.

The work bowl should not be placed in a microwave oven.

## WARRANTY LIMITED THREE-YEAR WARRANTY

This warranty supersedes all previous warranties on Cuisinart® SmartPower Premier Duet™ 600-Watt Blender/Food Processor. This warranty is available to consumers only. You are a consumer if you own a Cuisinart® SmartPower Premier Duet™

600-Watt Blender/Food Processor that was purchased at retail for personal, family, or household use. Except as otherwise required under applicable state law, this warranty is not available to retailers or other commercial purchasers or owners. We warrant that your Cuisinart® SmartPower Premier Duet™ 600-Watt Blender/Food Processor will be free of defects in material or workmanship under normal home use for three years from the date of original purchase. We suggest that you complete and return the enclosed product registration card promptly to facilitate verification of the date of original purchase. However, return of the product registration card does not eliminate the need for the consumer to maintain the original proof of purchase in order to obtain the warranty benefits. In the event that you do not have proof of purchase date, the purchase date for purposes of this warranty will be the date of manufacture.

If your blender should prove to be defective within the warranty period, we will repair it or, if we think it necessary, replace it. To obtain warranty service, please call our Consumer Service Center toll-free at 1-800-726-0190 or write to:

**Cuisinart**  
**150 Milford Road**  
**East Windsor, NJ 08520**

To facilitate the speed and accuracy of your return, please enclose \$10.00 for shipping and handling of the product. Please also be sure to include a return address, daytime phone number, description of the product defect, product serial number (stamped on bottom of product base), and any other information pertinent to the product's return. Please pay by check or money order. (California residents need only supply proof of purchase and should call 1-800-726-0190 for shipping instructions).

**NOTE:** For added protection and secure handling of any Cuisinart® product that is being returned, we recommend you use a traceable, insured delivery service. Cuisinart cannot be held responsible for in-transit damage or for packages that are not delivered to us. Lost and/or damaged products are not covered under warranty.

Your Cuisinart® SmartPower Premier Duet™ 600-Watt Blender/Food Processor has been manufactured to strict specifications and has been designed for use with the Cuisinart® SmartPower Premier Duet™ 600-Watt Blender/Food Processor accessories and replacement parts. These warranties expressly exclude any defects or damages caused by accessories, replacement parts, or repair service other than those that have been authorized by Cuisinart. These warranties do not cover any damage caused by accident, misuse, shipment, or other than ordinary household use. These warranties exclude all incidental or consequential damages. Some states do not allow the exclusion of or limitation of incidental or consequential damages, so the foregoing limitation may not apply to you.

## CALIFORNIA RESIDENTS ONLY

California law provides that for In-Warranty Service, California residents have the option of returning a nonconforming product (A) to the store where it was purchased or (B) to another retail store which sells Cuisinart® products of the same type. The retail store shall then, according to its preferences, either repair the product, refer the consumer to an independent repair facility, replace the product, or refund the purchase price less the amount directly attributable to the consumer's prior usage of the product. If either of the above two options does not result in the appropriate relief to the consumer, the

---

consumer may then take the product to an independent repair facility if service or repair can be economically accomplished.

\*Cuisinart and not the consumer will be responsible for the reasonable cost of such service, repair, replacement, or refund for nonconforming products under warranty.

California residents may also, at their preference, return nonconforming products directly to Cuisinart for repair or, if necessary, replacement by calling our Consumer Service Center toll-free at 1-800-726-0190. Cuisinart will be responsible for the cost of the repair, replacement, and shipping and handling for such nonconforming products under warranty.

## BEFORE RETURNING YOUR CUISINART PRODUCT

If you are experiencing problems with your Cuisinart® product, we suggest that you call our Consumer Service Center at 1-800-726-0190 before returning the product for servicing. Often, our Consumer Service Representatives can help solve the problem without having the product serviced. If servicing is needed, a Representative can confirm whether the product is under warranty and direct you to the nearest service location.

**\*Important:** If the nonconforming product is to be serviced by someone other than Cuisinart's Authorized Service Center, please remind the servicer to call our Consumer Service Center at 1-800-726-0190 to ensure that the problem is properly diagnosed, the product is serviced with the correct parts, and to ensure that the product is still under warranty.

# RECIPES

## SMOOTHIES, SHAKES, FRAPPÉS, FROZEN BEVERAGES

### FRESH FRUIT SMOOTHIE

*Layers of fresh fruit blend in just seconds to make this all-fruit smoothie.*

Makes six 8-ounce servings

- ½ **cup orange juice**
- 1 cup cantaloupe, cut into 1" pieces**
- 1 cup raspberries (fresh or frozen)**
- 1 cup pineapple chunks (1" pieces) (fresh or canned, drained)**
- 1 cup navel orange segments, cut into 1" pieces**
- 1 cup strawberries, hulled and halved**
- 1 cup mango chunks (1" pieces)**
- 1 medium banana, cut into ½" slices**
- 1 cup ice cubes (about 6 standard)**

Layer the ingredients in the blender jar in the order listed. Place cover on blender jar. Set blender speed on High. Turn blender on and blend for 20 to 30 seconds until smooth. Turn blender off.

Note: The riper the fruit, the sweeter the smoothie.

*Nutritional information per serving:  
Calories 101 (4% from fat) • carb. 25g • pro. 2g • fat 0g  
• sat. fat 0g • chol. 0mg • sod. 10mg • calc. 35mg • fiber 4g*

---

## FRUIT AND YOGURT SMOOTHIE

*A delicious drink for breakfast on the run.*

*The fruits may be varied to suit your own taste.*

*Add more calcium by using calcium-enriched orange juice.*

Makes 48 ounces

- 2 cups pineapple chunks**
- 1 medium banana, cut in 1" pieces**
- 1 cup orange juice**
- 1 cup fat-free vanilla yogurt**
- 2 cups frozen strawberries (do not thaw)**

Place all ingredients in blender jar in order listed. Set on High and blend until smooth and creamy, about 20 seconds.

Serve immediately or refrigerate.

*Nutritional information per serving (based on 6 servings):*

*Calories 105 (4% from fat) • carb. 25g • pro. 3g • fat 0g  
• sat. fat 0g • chol. 1mg • sod. 23mg • calc. 76mg • fiber 2g*

## TO-FRUITI SMOOTHIES

*The much-maligned tofu is a good source of protein and a nice alternative to using dairy products in smoothies.*

*Change the fruits to suit your own taste.*

Makes 48 ounces

- 1 cup mango chunks (1" pieces), about 12 ounces**
- 1 medium banana, cut in 1" pieces**
- 1 cup orange, apple or other fruit juice**
- 1 cup soy milk/beverage**
- 1 tablespoon vanilla extract**
- 1 cup silken tofu, cut into 1" pieces**
- 2 cups frozen strawberries (do not thaw)**

Place all ingredients in blender jar in order listed. Set on High and blend until smooth and creamy, about 20 seconds.

Serve immediately or refrigerate.

*Nutritional information per serving*

*(based on 6 servings): Calories 135 (18% from fat) • carb. 25g • pro. 5g • fat 2g  
• sat. fat 0g • chol. 0mg • sod. 10mg • calc. 63mg • fiber 4g*

## MONKEY-DOODLE SHAKE

*Chocolate frozen yogurt and bananas are combined to make this creamy shake.*

Makes 4 servings

- 2 cups lowfat milk**
- 2 bananas, peeled, cut into 1" pieces**
- 2 cups lowfat chocolate frozen yogurt**
- 2 tablespoons chocolate syrup**

Place all ingredients in blender jar in order listed; cover blender jar. Set on High and blend until smooth, creamy and thickened, about 40 to 50 seconds. Serve immediately in tall glasses with straws.

*Nutritional information per serving:*

*Calories 257 (18% from fat) • carb. 46g • pro. 8g • fat 5g  
• sat. fat 3g • chol. 19mg • sod. 95mg • calc. 216mg • fiber 2g*

## MOCHA FRAPPÉ

*Why go out for special coffee drinks when you can prepare them easily at home in your Cuisinart® Blender.*

Makes 2 servings

- 8 ounces espresso or double strength coffee, chilled\***
- ¼ cup chocolate sauce**
- 2 tablespoons flavored syrup – vanilla, hazelnut, almond, raspberry, etc.**
- 15 ice cubes**

Place all ingredients in blender jar in order listed. Cover blender jar. Set on High and blend until smooth and slushy, about 30 to 40 seconds. Serve immediately in tall glasses. Garnish with a dollop of whipped cream if desired.



---

*Nutritional information per serving:*  
Calories 138 (0% from fat) • carb. 33g • pro. 1g • fat 0g  
• sat. fat 0g • chol. 0mg • sod. 37mg • calc. 6mg • fiber 0g

For a Creamy Frappé, add 2 tablespoons half-and-half before blending.

\* May be prepared from instant espresso powder.

## FROZEN MANGO MARGARITAS

*You can make Margaritas and other frozen drinks with ease with your Cuisinart® Blender – try this refreshing Mango Margarita, or use your own special recipe.*

Makes 6 servings

- 2 cups mango cubes (fresh or frozen, partially thawed)**
- ½ cup Tequila**
- ¼ cup Triple Sec or Cointreau®**
- ¼ cup fresh lime juice**
- 4 tablespoons superfine sugar**
- 2 cups ice cubes**

Place all ingredients in blender jar in order listed. Place cover on blender jar. Blend on High for 30 to 40 seconds until the mixture is smooth and slushy in texture. Turn blender off. Serve immediately.

*Nutritional information per serving:*  
Calories 158 (1% from fat) • carb. 23g • pro. 0g • fat 0g  
• sat. fat 0g • chol. 0mg • sod 5mg • calc. 9mg • fiber 1g

Note: For an alcohol free “Margarita,” substitute 8 ounces fruit juice, such as apricot nectar or cranberry juice, for the Tequila and Triple Sec.

Cointreau® is a registered trademark owned by the the Cointreau Corporation.

## FROZEN COSMOPOLITAN

*Can you improve on a new classic? Of course!  
Try our Frozen Cosmopolitan.*

Makes 8 servings

- 2 cups cranberry juice**
- 10 ounces chilled vodka (may use citrus flavored)**
- 2 ounces lime juice**
- 2 ounces Triple Sec or Cointreau® lime twists for garnish**

Pour the cranberry juice into ice cube trays and freeze until solid. Place the vodka, lime juice, Triple Sec and frozen cranberry cubes in the blender jar in order given. Set on High and blend for 25 to 30 seconds until completely slushy. Serve immediately in chilled martini or other stemmed glasses, garnished with a twist of lime.

*Nutritional information per serving:*  
Calories 142 (1% from fat) • carb. 12g • pro. 0g • fat 0g  
• sat. fat 0g • chol. 0mg • sod. 2mg • calc. 3mg • fiber 0g

## FROZEN DAIQUIRI

*A classic frozen cocktail.*

Makes 4 servings

- 6 ounces frozen limeade**
- 5 ounces light rum**
- 3 cups ice cubes**

Place ingredients in blender jar in order listed. Cover blender jar. Set on High. Turn on blender jar and process until smooth and slushy, about 30 to 40 seconds. Turn blender off. Serve immediately.

*Nutritional information per serving:*  
Calories 92 (0% from fat) • carb. 14g • pro. 0g • fat 0g  
• sat. fat 0g • chol. 0mg • sod. 2 mg • calc. 2mg • fiber 0g

For Frozen Fruit Daiquiris, add 2-3 cups fruit (strawberries, peaches, melon, etc.) cut into 1" pieces. For a more pronounced fruit flavor, freeze additional fruit in cubes and use in place of ice cubes.

---

## SOUPS, SPREADS, DIPS AND MORE

For best results when blending fresh herbs, the herbs, blender jar and cutting assembly must be dry and clean.

### CHILLED GAZPACHO

*A Cuisinart favorite, made with fresh, ripe summer tomatoes, Chilled Gazpacho is perfect on a hot, summer night.*

Makes 8 servings, about 6 ounces each

- 1-2 cloves garlic, peeled**
- 3 cups tomato or vegetable juice cocktail, divided**
- 1 large rib celery, peeled, cut into 1" pieces**
- 1 large cucumber, peeled, halved lengthwise, seeded, cut into 1" pieces**
- ½ medium green bell pepper, cored, seeded, cut into 1" pieces**
- ½ medium red bell pepper, cored, seeded, cut into 1" pieces**
- 1 large jalapeño pepper, cored, seeded, cut into ½" pieces**
- 6 green onions, trimmed, cut into ½" pieces**
- 4 medium tomatoes, cored, seeded, cut into 1" pieces**
- 3 tablespoons sherry vinegar or lemon juice**
- ½ teaspoon kosher salt**
- ¼ teaspoon freshly ground black pepper**

Place garlic in blender jar; cover jar. Set on Low; pulse to chop garlic, 10 times. Add 1 cup tomato juice/vegetable juice cocktail to blender jar along with celery, cucumber, green pepper, red pepper, jalapeño pepper, and green onions. Blend on Low until vegetables are medium-finely chopped, about 5 to 10 seconds. Transfer to a large serving bowl. Add remaining tomato juice/vegetable cocktail to blender jar with fresh tomatoes.

With blender set on Low, pulse 10 times to chop, or blend continuously if a smoother gazpacho is preferred.

Add to the bowl of vegetables with the remaining juice. Season with sherry vinegar or lemon juice, salt and pepper. Chill before serving.

*Nutritional information per serving:  
Calories 51 (5% from fat) • carb. 11g • pro. 2g • fat 0g  
• sat. fat 0g • chol. 0mg • sod. 429mg • calc. 28mg • fiber 2g*

### CHILLED MELON AND MANGO SOUP

*Sweet cantaloupe and mango combine with orange juice for this refreshing cold soup. Perfect for a summer brunch or as a refreshing, cool ending to a warm-weather meal.*

Makes 8 servings

- 2-3 slices fresh ginger (each about the size of a quarter)**
- 1 mango, about 12 -14 ounces, peeled, seeded, cut into 1" pieces**
- 1 cantaloupe, about 3 pounds, peeled, seeded, cut into 1" pieces**
- ½-1 cup orange juice**

Place ginger, mango, melon and ½ cup orange juice in the blender jar; cover. Set on Low and blend until smooth, about 20 to 30 seconds. Add as much remaining orange juice as necessary to adjust consistency to that of a thick soup. Chill completely before serving. May be garnished with fresh raspberries or blueberries and a sprig of mint.

*Nutritional information per serving:  
Calories 68 (2% from fat) • carb. 17g • pro. 1g • fat 0g  
• sat. fat 0g • chol. 0mg • sod. 14mg • calc. 17mg • fiber 1g*

### CREAM OF ASPARAGUS SOUP

*Make this soup in the spring when asparagus is at its most flavorful.*

Makes eight 6-ounce servings

- ¾ cup Italian parsley leaves, washed and dried**
- 3 tablespoons unsalted butter**
- ¾ cup chopped onion or leek**
- 1 pound asparagus, trimmed, cut into 1" pieces**
- 3 cups fat free, low-sodium chicken or vegetable stock or broth**
- 1 cup half-and-half**

- 
- 1** tablespoon cornstarch
  - 1½** cups cold water
  - 1** teaspoon kosher salt
  - ½** teaspoon white pepper

Place the parsley in the blender jar. Place cover on blender jar. Set blender on Low and pulse until coarsely chopped, about 4 to 5 times. Remove and reserve.

Melt the butter in a medium Cuisinart® saucepan over medium heat. Add onion and cook until soft but not brown, about 2 to 3 minutes. Add asparagus, stock, and all but 1 tablespoon of the reserved parsley. Cover and bring to a boil over medium-high heat. Reduce heat to low and simmer, partially covered, until asparagus is tender, about 10 to 12 minutes.

Pour the soup through a strainer, reserving the solids and liquids. Allow to cool 5 minutes. Place the solids in the blender jar with 1 cup of the cooking liquid; return the remaining liquid to the saucepan. Cover blender jar and set on Low. Turn blender on and blend until creamy and smooth, about 25 to 30 seconds. Turn blender off. Return puréed vegetable mixture to the saucepan and stir to combine. Stir in half-and-half. Stir cornstarch into water, and add to soup. Add salt and pepper. Cook, stirring often, over medium heat, until soup thickens, about 6 to 8 minutes. Do not allow to boil. Taste and adjust seasonings as needed. Serve in warmed bowls garnished with the remaining parsley.

*Nutritional information per serving:*  
Calories 98 (59% from fat) • carb. 7g • pro. 4g • fat 7g  
• sat. fat 4g • chol. 19mg • sod. 510g • calc. 56mg • fiber 2g

## CREAMY POTATO LEEK SOUP

*This versatile soup may be served hot or chilled.*

Makes 6 servings

- 2** medium leeks, white and tender green only, sliced horizontally and cut into ½" pieces
- 1** tablespoon unsalted butter
- 1** small (3-4 ounce) onion, peeled and cut into ½" pieces
- ¼** teaspoon thyme
- 2** medium russet potatoes (about ¾ pound total),

peeled, cut into 1" slices

- 1½** cups fat-free, low-sodium chicken stock or broth
- ¾** cup water
- 1** teaspoon kosher salt
- ½** teaspoon white pepper
- ¾** cup half-and-half

Place leeks in a medium bowl and add cold water. Swirl, then let stand for minutes. Lift leeks from the water without disturbing the sand/sediment collected in the bowl; allow to drain completely.

Melt butter in a large Cuisinart® saucepan over medium heat. Add the drained leeks, onion, and thyme. Let cook until softened, 3 to 5 minutes. Add potatoes, stock, and water; cover and bring to a boil over medium high heat. Reduce heat to low, and simmer, uncovered, until potatoes are soft, about 10 to 15 minutes.

Drain vegetables, reserving cooking liquid. Place vegetables in blender jar. Add 1 cup cooking liquid; return remaining cooking liquid to saucepan. Cover blender jar. Set on High. Blend 20 to 30 seconds. Scrape blender jar and blend 10 to 15 seconds longer, until completely puréed and creamy smooth. Stir vegetable purée into stock in saucepan and reheat over medium low heat. Add salt, pepper and half-and-half.

*Nutritional information per serving:*  
Calories 132 (37% from fat) • carb. 18g • pro. 3g • fat 6g  
• sat. fat 3g • chol. 16mg • sod. 369mg • calc. 56mg • fiber 3g

**Variation:** Turn this soup into Creamy Watercress Soup by adding 1 bunch watercress, washed and dried. Pick leaves and reserve. Chop stems and measure out 1½ cups. Add stems to vegetable mixture when sautéing. Follow recipe as directed.

Stir in reserved watercress leaves along with the half-and-half. Serve hot or chilled.

---

## CREAMY TOMATO AND RED PEPPER BISQUE

*Creamy tomato soup that is special enough for any occasion.*

Makes 8 servings

- 1** teaspoon unsalted butter
- 1** teaspoon extra virgin olive oil
- 1** small onion (4 ounces), peeled, cut in ½" pieces
- 1** rib celery (2 ounces), cleaned, cut in ½" pieces
- 1** carrot (2 ounces), peeled, cut in ½" pieces
- 2** tablespoons white rice
- 1** teaspoon basil
- 2** cups fat free, low-sodium chicken or vegetable stock
- 2** cans recipe ready diced tomatoes (15½ oz.) with juices
- 2** roasted red peppers, seeded
- ½ teaspoon kosher salt
- ½ teaspoon white pepper
- ½ cup half-and-half

Heat the butter and olive oil in a Cuisinart® 3¼-quart saucepan over medium low heat. Add the onion, celery, and carrot; cover loosely and cook until the vegetables are tender, 8-10 minutes. Stir in the rice and basil; cook until rice is opaque, 2 minutes. Stir in the stock, tomatoes and roasted red peppers. Raise heat and bring to a boil. Lower the heat, cover loosely and simmer over low heat for 20-25 minutes. Turn off heat and let stand for 5 minutes.

Strain the solids from the cooking liquid, reserving the cooking liquid and returning it to the saucepan. Place the solids in the blender jar. Add 1 cup of the cooking liquid to the blender jar. Set on High. Pulse 10 times to chop, then process for 30 to 40 seconds until totally smooth and creamy. Add the salt and pepper; blend 5 seconds longer. Return the blended tomato mixture to the cooking liquid in the saucepan. Heat on medium until it just begins to simmer, then add the half-and-half. Do not allow to boil. The soup may be made ahead and reheated – if making ahead, do not add half-and-half until soup is reheated.

*Nutritional information per serving:*

*Calories 87 (28 % from fat) • carb. 13g • pro. 3g • fat 3g  
• sat. fat 1g • chol. 7mg • sod. 367mg • calc. 47mg • fiber 3g*

## PERFECT POPOVERS

*Impress your guests with these deceptively simple popovers that are mixed in a matter of seconds in your Cuisinart® Blender. Our 50-ounce blender is large enough for you to increase this recipe by 50 percent to make a larger batch.*

Makes 18 popovers

- 6** large eggs
- 2** cups all-purpose flour
- 2** cups evaporated fat-free milk, not reconstituted
- ½ teaspoon kosher salt
- 5** tablespoons unsalted butter, melted

Preheat oven to 375°F. Thoroughly coat eighteen ½-cup popover, custard, or muffin cups with cooking spray or melted butter.

Place the eggs, flour, milk and salt in the blender jar in the order listed; cover blender jar. Set on Low. Blend for 10 seconds. Scrape the sides of the jar if needed. With the blender running, add the melted butter in a steady stream and blend for 10 seconds. Let batter rest for 10 to 15 minutes.

Divide the batter evenly among the prepared pans. Bake in the preheated oven until puffy and nicely browned, about 40 minutes. Use a cake tester to pierce each popover several times and bake for an additional 5 minutes. Remove from oven, loosen from pans with a thin-blade knife and gently lift out. Serve hot.

*Nutritional information per popover:*

*Calories 126 (37% from fat) • carb. 14g • pro. 6g • fat 5g  
• sat. fat 3g • chol. 79mg • sod. 91mg • calc. 93mg • fiber 0g*

**For Pesto Popovers:** add ½ cup prepared pesto (page 18) to the batter. Bake as directed.

## ROASTED GARLIC HUMMUS

Makes about 2½ cups

- 2** tablespoons Italian parsley leaves
- 8-12** cloves roasted garlic, cooled \*
- 2** cups canned chickpeas, rinsed and drained

- ½ **cup fresh lemon juice**
- ¼ **cup tahini**
- 2 teaspoons kosher salt**
- ½ **teaspoon cumin**
- 2 tablespoons extra virgin olive oil**

Place the parsley in the work bowl fitted with the chopping blade. Place cover on work bowl and press On button, then the Pulse button, and the Food Processor Button to pulse, 8-10 times. Remove and reserve. Place the roasted garlic, chickpeas, lemon juice, tahini, salt, and cumin in the work bowl. Press the On button and process on High Speed until smooth, about 30-40 seconds. With the machine running, add 1½ tablespoons of the olive in a slow, steady stream, about 20 seconds, processing until completely blended. Press Off button. Transfer to a serving dish, drizzle with remaining olive oil and sprinkle with the reserved chopped parsley. Serve at room temperature with wedges of pita bread, toasted pita chips or vegetable crudités.

\*To roast garlic, peel as many cloves as you need (it will keep refrigerated for a week in an airtight container, so do lots to have on hand), and toss them in a small amount of olive oil. Place them in the center of a sheet of heavy-duty aluminum foil and roast in a 400°F oven for 35-45 minutes until tender and golden. The sharp pungent flavor of the garlic will become sweet and mellow.

*Nutritional information per 1/3 cup serving:*  
*Calories 181 (50% from fat) • carb 17g • pro 7g • fat 10g*  
*• sat fat 1g • chol 0mg • sod 389mg • calc 60mg • fiber 6g*

## GUACAMOLE

Makes 1 cup

- 1 small clove garlic**
- 2 medium ripe avocados, approximately 1 cup of pulp**
- 2 teaspoons lemon juice**
- ½ **teaspoon salt**
- ¼ **teaspoon chili powder**

Place the garlic in the work bowl fitted with the chopping blade. Turn machine On and process on High until finely chopped, about 10 seconds. Add remaining ingredients to bowl and pulse on High for

approximately 1½ minutes, until the mixture is completely smooth and creamy.

Serve immediately or cover the guacamole directly with plastic wrap to avoid oxidation.

*Nutritional information per 1/4 cup serving:*  
*Calories 104 (79% from fat) • carb 5g • pro 1g • fat 10g*  
*• sat fat 1g • chol 0mg • sod 301mg • calc 9mg • fiber 3g*

## GRAPE TOMATO SALSA

Makes about 1 cup

- ¼ **cup fresh cilantro leaves**
- 1 small garlic clove, peeled**
- 1 jalapeño pepper, halved, seeded, cut into ½ inch pieces**
- 1 green onion, trimmed (include some green), cut in ½-inch pieces**
- 1 pint grape tomatoes**
- 1 teaspoon fresh lime juice**
- 1 teaspoon kosher salt**

Place cilantro in the work bowl fitted with the chopping blade. Place cover on bowl and press the On button. With the food processor running on high speed, add garlic through the feed tube and process until finely chopped, about 5 seconds. Scrape work bowl. Add jalapeño, onion, tomatoes, lime juice, and salt. Press the Pulse button and pulse on high speed until coarsely chopped, about 8-10 times.

*Nutritional information per tablespoon:*  
*Calories 8 (9% from fat) • carb. 2g • pro. 0g • fat 0g*  
*• sat. fat 0g • chol. 0mg • sod. 170mg • calc. 4mg • fiber 0g*

---

## MEDITERRANEAN TUNA

Makes 1 cup

- ½ **ounce red onion**
- 1 6-ounce can tuna packed in oil\***
- 1½ **tablespoon capers**
- 1 tablespoon fresh parsley**
- 1 teaspoon lemon juice**
- ½ **teaspoon dried oregano**
- ¼ **teaspoon salt**
- 1 teaspoon extra virgin olive oil (optional)**

Place the red onion in the work bowl fitted with the chopping blade. Place cover on work bowl and press On button. Process on High to chop onion finely, about 15 seconds. Add tuna, 1 tablespoon of capers, parsley, lemon juice, oregano, and salt. Press Pulse button and pulse on High until tuna mixture is well blended about 6-8 times. If the tuna mixture appears to be dry, pulse in the optional teaspoon of olive oil.

Add last ½ tablespoon of capers and pulse 2-3 times to maintain some texture of the capers. Transfer to a serving dish or resealable container. Cover and refrigerate if not serving immediately.

\*The imported Italian tuna packed in olive oil has the best flavor for this recipe.

*Nutritional information per 1/4 cup serving:*  
Calories 88 (37% from fat) • carb 1g • pro 13g • fat 4g  
• sat fat 1g • chol 8mg • sod 288mg • calc 13mg • fiber 0g

## ARTICHOKE TAPENADE

Makes 1 cup

- 2 tablespoons pine nuts, toasted**
- 1 14-ounce can artichoke hearts, drained**
- 2 sun-dried tomato halves, sliced**
- 1 tablespoon green onion**
- ¼ **cup (packed) fresh Italian parsley leaves**

- 1 teaspoon extra virgin olive oil**

- ¼ **teaspoon kosher salt**

Place the pine nuts in the work bowl fitted with the chopping blade. Place cover on work bowl and press On button, then the Pulse button, and pulse on High Food Processor Button until finely ground. Add the remaining ingredients and pulse on High until all ingredients are incorporated and smooth.

Serve with crackers or vegetables as a dip.

*Nutritional information per 1/4 serving:*  
Calories 88 (41% from fat) • carb 11g • pro 3g • fat 4g  
• sat fat 1g • chol 0mg • sod 699mg • calc 12mg • fiber 3g

## ENDIVE WITH SHRIMP FILLING

*A great finger food, not too fussy, and easy to do ahead.*

Makes 30 appetizers (1¼ cups shrimp filling)

- 2 tablespoons fresh parsley leaves**
- 2 shallots, peeled and quartered**
- 1 tablespoon unsalted butter**
- 1 teaspoon dill weed**
- 6 ounces cooked, peeled and deveined shrimp, cut in 1-inch pieces**
- 4 ounces lowfat cream cheese, cut into 1-inch pieces**
- 2 -3 Belgian endive (30 leaves)**

Place the parsley in the work bowl fitted with the chopping blade. Turn ON and process until finely chopped, about 10 seconds; remove and reserve. Place shallots in work bowl; press Pulse. Pulse on High to chop finely, about 10 pulses. Heat butter in a Cuisinart® 8-inch non-stick skillet over medium heat. Add shallot and cook, stirring, until golden brown, about 5 to 6 minutes. Turn off heat and stir in dill weed. Set aside to cool.

Add shrimp to work bowl; pulse to chop, 5 times. Remove and reserve. Process cream cheese until smooth and creamy, about 15 seconds; scrape work bowl. Add half the reserved parsley, cooled shallot mixture, and chopped shrimp. Pulse to combine, about 8 times.

Trim ½ inch from bottom of endive leaves. Separate into individual

---

leaves and choose 30 of the nicest leaves. Pipe or spread a small amount (2 teaspoons) of shrimp/cream cheese mixture onto bottom half of leaves. Arrange on flat serving dish. Cover and refrigerate until ready to serve. Sprinkle lightly with remaining reserved chopped parsley just before serving.

*Nutritional information per serving (one filled endive leaf):*

*Calories 27 (43% from fat) • carb. 2g • pro. 2g • fat 1g  
• sat. fat 1g • chol. 15mg • sod. 41mg • calc. 33mg • fiber 2g*

## ROOT VEGETABLE GRATIN

Serves 8

**cooking spray**

**1½ cup heavy cream**

**2 cloves garlic, smashed**

**¼ teaspoon dried rosemary**

**8 ounces red-skinned or Yukon gold potatoes, peeled, cut to fit feed tube**

**4 ounces sweet potatoes, peeled, cut to fit feed tube**

**8 ounces yam, peeled, cut to fit feed tube**

**4 ounces parsnip, peeled**

**2 teaspoons kosher salt**

**1 teaspoon freshly ground pepper**

Place all peeled vegetables in a bowl and submerge them in cold water.

Preheat oven to 375°F. Lightly coat a 1¼ quart ovenproof baking dish with cooking spray.

In a small saucepan, place cream, smashed garlic, and rosemary. Heat the cream until it just barely boils (this is scalding). Reduce heat and simmer for 10 minutes.

While cream simmers, insert the slicing disc into the work bowl. Arrange root vegetables in feed tube. Press On, then High to slice the vegetables, using medium pressure.

Arrange sliced vegetables in prepared dish by overlapping them slightly in a circular pattern. Continue creating new layers of

vegetables until they are all used. Season each layer generously with salt and pepper. Finish by pouring the warm cream over the vegetables. Cover with a sheet of aluminum foil that has been lightly coated with cooking spray. Place in middle of oven on a baking sheet and bake for 45 minutes. Remove foil and continue baking for about another 30 minutes until gratin is golden and bubbly. Remove from oven and let rest 5-10 minutes. Serve hot.

*Nutritional information per serving:*

*Calories 235 (62% from fat) • carb 21g • pro. 2g • fat 17g  
• sat fat 10g • chol 61mg • sod 613mg • calc 46 mg • fiber 3g*

## POTATO PANCAKES

Makes eight 2-inch pancakes

**12 ounces Yukon gold potatoes, peeled, cut to fit feed tube**

**2 ounces yellow onion**

**1 green onion (1 tablespoon chopped)**

**1 egg, lightly beaten**

**1 teaspoon kosher salt**

**2 tablespoon vegetable oil**

Place the green onion in the work bowl of the fitted with the chopping blade. Press On button and process on high until finely chopped. Insert the shredding disc and place cover on work bowl. Place potatoes in feed tube and shred using high speed. Continue with any remaining potatoes and then the yellow onion. Transfer contents of work bowl to a clean tea towel which has been laid out on the counter. Over the sink or mixing bowl, use the tea towel to wring out as much liquid as you can from the potatoes and onion. Transfer ingredients to a mixing bowl. Add egg, salt, and pepper and mix well.

Place a nonstick 10-inch skillet over medium heat. Add the vegetable oil. Form small pancakes with your hands, squeezing out any remaining liquid. When the oil shimmers in the pan, add pancakes. Cook approximately 3 minutes on each side until pancake is golden brown or to your desired doneness.

*Nutritional information per pancake:*

*Calories 76 (47% from fat) • carb 8g • pro 2g • fat 4g  
• sat fat 1g • chol 27mg • sod 304mg • calc 9mg • fiber 1g*

---

## SHREDDED CARROT AND ZUCCHINI SALAD

*A quick and easy salad for all seasons.*

Makes 4 servings

- 2 small zucchini (a scant ½ pound), cut to fit feed tube**
- 3 medium carrots (a scant ½ pound), peeled, cut to fit feed tube**
- ½ small clove garlic, peeled**
- 2 tablespoons raspberry vinegar**
- 1 teaspoon Dijon-style mustard**
- ¼ teaspoon kosher salt**
- ¼ teaspoon freshly ground pepper**
- ¼ cup light olive oil**
- 2 tablespoons toasted slivered almonds**

Insert the shredding disc in the work bowl and place cover on work bowl. Press On. Place zucchini in feed tube; press High and shred using medium pressure. Transfer to a medium bowl. Place carrots in feed tube and shred using firm pressure. Press Off. Transfer to the bowl with the zucchini; toss to combine. Do not clean work bowl.

Insert the chopping blade in work bowl. Place cover on work bowl and press On button, then High. With the machine running, drop the garlic through the feed tube and process to chop, 5 seconds. Press Off. Scrape the work bowl and add the vinegar, mustard, salt, and pepper. Press On, then High. Process 5 seconds to combine, then, with the machine running, add the oil slowly through the feed tube and process until emulsified, about 30 seconds. Press Off.

Toss the shredded zucchini and carrots with dressing to taste. Transfer to a serving bowl and garnish with slivered toasted almonds. Serve immediately or cover and chill for up to 2 hours (vegetables will begin to lose their crunchy freshness if longer).

*Nutritional information per 1/4 cup serving:*  
Calories 183 (76% from fat) • carb. 9g • pro. 2g • fat 16g  
• sat. fat 2g • chol. 0mg • sod. 137mg • calc. 37mg • fiber 3g

## ASIAN SLAW

Makes 4 cups

- 2 tablespoons fresh cilantro**
- 6½ ounces red cabbage**
- 6½ ounces green (savoy) cabbage**
- 2 ounces red onion**
- 1 inch piece fresh ginger, peeled**
- 2 tablespoons fresh cilantro**
- 2 tablespoons unseasoned rice vinegar**
- ¼ cup vegetable oil**
- 2 tablespoons granulated sugar**
- ¾ teaspoon kosher salt**

Add the cilantro to the work bowl fitted with the chopping blade. Press On button and finely chop the cilantro using the high speed. Cut the cabbage and onion to fit the feed tube of the processor. Insert the slicing blade to the food processor bowl. Slice the cabbage and then the onion. Place vegetables in a mixing bowl after slicing. Turn the slicing blade over to the shredder and process ginger, place in the mixing bowl. Transfer to bowl with vegetables.

Insert the chopping blade. Add the rice vinegar, vegetable oil, sugar, and salt to the work bowl. Press On, then High to process until blended and emulsified, about 15 seconds. Makes about ½ cup dressing. Add dressing to taste to salad and toss.

*Nutritional information per 1/2 cup serving:*  
Calories 84 (71% from fat) • carb 6g • pro 1g • fat 7g  
• sat fat 2g • chol 0mg • sod 228mg • calc 23mg • fiber 1g



---

## SAUCES AND DRESSINGS

### PESTO

Makes about ¾ cup

- 1 ounce Parmigiano-Reggiano, cut in ½-inch cubes**
- ¼ cup toasted pine nuts or walnuts**
- 1 clove garlic, peeled**
- 1 cup (packed) fresh basil leaves, washed and dried completely**
- ¼ cup extra virgin olive oil**
- ½ teaspoon kosher salt**

Insert the chopping blade in the food processor work bowl of the SmartPower Premier Duet™. Turn On and press High. With the machine running, drop the cheese through the feed tube and process to chop finely, about 10 to 15 seconds; remove and reserve. Place the nuts in the work bowl and Pulse to chop, 5 times; remove and reserve. With the machine running, drop the garlic through the feed tube and process to chop, 5 seconds. Scrape work bowl. Add basil leaves to work bowl. Pulse to chop, 5 times, then process until finely chopped, about 5 seconds. With the machine running, add the olive oil in a steady stream to create a smooth emulsion. Scrape work bowl. Add salt, reserved Parmesan cheese and chopped nuts to work bowl. Process until smooth and blended, about 10 seconds. Transfer to a resealable container, cover with a thin layer of olive oil, cover and refrigerate until ready to use. Pesto may be frozen.

*Nutritional information per serving (1 tablespoon):*

*Calories 81 (86% from fat) • carb. 1g • pro. 2g • fat 8g  
• sat. fat 1g • chol. 2mg • sod. 69mg • calc. 42mg • fiber 0g*

### RUSTIC TOMATO SAUCE

*Healthy and delicious at the same time!*

Makes about 8 cups

- 1 tablespoon extra virgin olive oil**
- 1 onion (8 ounces), peeled and cut in ½" pieces**

- 2 carrots (4 ounces), peeled and cut in ½" pieces**
- 2 ribs celery, trimmed and cut in ½" pieces**
- 4 cloves garlic, peeled**
- 1 teaspoon dried oregano**
- 1 teaspoon dried basil**
- 4 roasted red bell peppers, cut in 1" pieces**
- ½ cup dry white wine (such as vermouth)**
- 2 tablespoons tomato paste**
- 3 cans (15-ounce) recipe ready diced tomatoes with juices**
- ½ teaspoon kosher salt**
- ¼ teaspoon freshly ground black pepper**

In a Cuisinart® 3¼-quart saucepan, heat the olive oil over medium heat. Add the onion, carrot, celery, garlic, oregano and basil.

Cover loosely and cook until the vegetables are softened, 6 to 8 minutes. Stir in the roasted red peppers, wine, tomato paste, and tomatoes. Bring to a boil, then reduce heat and simmer for 35 to 40 minutes, loosely covered. Uncover and simmer for 15 to 20 minutes longer to thicken. Turn off heat and let sit 5 minutes.

Strain the solids from the liquids, and return the liquid to the saucepan. Place the solids in the blender jar with ½ cup of the cooking liquid. Cover the blender jar. Set on Low and Pulse 10 times to chop. Use a plastic spatula to scrape the sides of the blender jar. Blend for 20 to 30 seconds, until smooth. Return the puréed tomato mixture to the liquid in the saucepan and reheat gently over medium low heat. Add salt and pepper.

*Nutritional information per half cup serving:*

*Calories 48 (17% from fat) • carb. 8g • pro. 1g • fat 1g  
• sat. fat 0g • chol. 0mg • sod. 194mg • calc. 26mg • fiber 2g*

### BASIC VINAIGRETTE

*This basic vinaigrette is perfect for a crisp green salad.*

Makes about 1½ cups – can be doubled

- 1 clove garlic, peeled**
- 2 tablespoons Dijon-style mustard**

- ½ **cup wine vinegar**
- 1 teaspoon kosher salt**
- ½ **teaspoon freshly ground pepper**
- ¾ **cup extra virgin olive oil**
- ¾ **cup vegetable oil**

Place the garlic in the blender jar and cover jar. Set on Low. Use the Pulse function to chop the garlic, 5 times. Add the mustard, vinegar, salt and pepper. Turn the blender on and blend for 10 to 15 seconds. With the blender running, add the oils in a slow, steady stream, taking about 20 seconds, then blend for 20 seconds longer until completely emulsified.

You may change the Basic Vinaigrette by changing the flavor of the vinegar, mustard or oil. Try using fresh lemon juice and a little honey for a honey-mustard vinaigrette.

Add fresh herbs, sun-dried tomatoes, or pesto for other flavor changes.

*Nutritional information per tablespoon:*  
*Calories 109 (97% from fat) • carb. 1g • pro. 0g • fat 12g*  
*• sat. fat 2g • chol. 0mg • sod. 86mg • calc. 1mg • fiber 0g*

## **CRACKED PEPPER PARMESAN DRESSING**

*A great dressing for pasta salad.*

Makes 1½ cups

- 2 teaspoons whole black peppercorns**
- 1 ounce Parmigiano-Reggiano, cut in ½" or smaller cubes**
- 1 shallot, about 1 ounce, peeled, cut in ½" or smaller pieces**
- 1 clove garlic, peeled and smashed**
- ½ **teaspoon kosher salt**
- 1 tablespoon Dijon-style mustard**
- ¼ **teaspoon Worcestershire sauce**
- 2 tablespoons light mayonnaise**
- ¼ **cup wine vinegar**
- ¼ **cup extra virgin olive oil**

- ¼ **cup canola or other flavorless vegetable oil**

Place the whole peppercorns in the blender jar. Blend for 10 seconds. Some peppercorns will be pulverized, some will be cracked and crushed; remove and reserve. Place the Parmesan cubes in the blender jar; blend for 20 seconds; scrape sides of blender jar. Add shallot, garlic and salt. Blend for 10 seconds; scrape sides of blender jar.

Add remaining ingredients in order listed; blend for 10 seconds. Add reserved black pepper; blend for 5 seconds. Transfer dressing to a resealable container and refrigerate for 30 minutes or longer to allow flavors to develop. Keeps for one week in the refrigerator.

*Nutritional information per tablespoon:*  
*Calories 58 (90% from fat) • carb. 1g • pro. 1g • fat 6g*  
*• sat. fat 1g • chol. 1mg • sod. 74mg • calc. 18mg • fiber 0g*

## **JAPANESE CARROT GINGER DRESSING**

*This dressing is served on the iceberg lettuce salad that often accompanies sushi. It is simple to prepare at home in your Cuisinart® Smart Power Premier Duet™ 600-Watt Blender.*

Makes about 2 cups

- 4 carrots, peeled, and cut into ½" slices**
- 1 piece ginger root, about 2 inches, peeled, cut in ½" pieces**
- 1 shallot, peeled, cut in 4 pieces**
- 1 clove garlic, peeled**
- 1 teaspoon dry mustard**
- ½ **cup apple juice**
- ⅓ **cup rice vinegar**
- ¼ **cup water**
- 2 tablespoons mirin (Japanese rice wine)**
- 1 tablespoon soy sauce**
- 1 tablespoon Asian sesame oil**

Place all ingredients in blender jar in order listed; cover blender jar. Blend on High for 30 to 40 seconds. Serve with chopped crisp lettuce.

---

*Nutritional information per serving (2 tablespoons):*  
Calories 26 (30% from fat) • carb. 4g • pro. 0g • fat 0g  
• sat. fat 0g • chol. 0mg • sod. 68mg • calc. 7mg • fiber 4g

## WASABI GINGER SAUCE/MARINADE

*Use this versatile sauce as a marinade for meats and seafood, a dressing for salads, or a dipping sauce for potstickers, dumplings or Mongolian Hot Pot.*

Makes about 2 cups

- ½ **ounce fresh ginger, peeled, cut in ½" or smaller pieces**
- 1 small shallot (½ ounce), peeled, cut in ½" or smaller pieces**
- 1 clove garlic, peeled**
- ¾ **cup mirin or rice wine\***
- ¾ **cup low-sodium soy or tamari sauce**
- ¼ **cup seasoned rice or wine vinegar**
- 2 tablespoons dark molasses**
- 2 tablespoons prepared wasabi paste\***
- 1 tablespoon brown sugar, packed**
- 1 tablespoon Asian sesame oil (toasted sesame oil)**
- 2 teaspoons powdered ginger**
- ½ **teaspoon freshly ground black pepper**

Place fresh ginger, shallot and garlic in blender jar; cover blender jar. Set on Low; Pulse 5 times. Scrape sides of jar; Pulse 5 times. Add remaining ingredients in order given. Blend for 20 seconds. Transfer to a resealable container and let stand for 30 minutes before using to allow flavors to develop. Unused portions may be refrigerated for up to a week; stir before using.

\* Available in Asian markets or gourmet/ethnic foods section of grocery stores.

Tip: Use about 1 tablespoon of marinade per portion. Meats such as boneless, skinless chicken parts, pork chops, or steaks may be placed in a resealable freezer weight bag, coated with marinade and frozen. When thawed, they will be fully marinated and ready to cook.

*Nutritional information per tablespoon:*  
Calories 22 (18% from fat) • carb. 3g • pro. 0g • fat 0g  
• sat. fat 0g • chol. 0mg • sod. 183mg • calc. 14mg • fiber 0g

## CAJUN CREOLE SPICE BLEND

*Our Cajun Creole Spice Blend is a comparable alternative to purchased spice mixtures, but much fresher and more economical. Adjust the spiciness to taste with the amount of cayenne used.*

Makes about ½ cup

- 2 teaspoons coriander seed**
- 1 teaspoon mustard seed**
- ½ **teaspoon celery seed**
- ½ **teaspoon white peppercorns**
- ½ **teaspoon black peppercorns**
- 1 bay leaf, roughly broken**
- 3 tablespoons sweet paprika**
- 1 tablespoon kosher salt**
- ½ **tablespoon sugar**
- 2 teaspoons dried minced garlic**
- 2 teaspoons minced dry onions**
- 1-2 teaspoons cayenne pepper, to taste**
- 2 teaspoons dry oregano**
- 1 teaspoon dry thyme leaves**
- 1 teaspoon dry basil**
- ½ **teaspoon dry rosemary**
- ½ **teaspoon ground allspice**

Place the coriander seed, mustard seed, celery seed, both peppercorns, and bay leaf in the blender jar. Cover jar and set on Low. Blend until seeds are finely ground, 10 to 15 seconds. Add the remaining ingredients and blend until no signs of the bay leaf are visible, about 20 to 30 seconds.

Use as a rub for meat, poultry, or seafood before sautéing, roasting or grilling, or add as a seasoning to rice or dressing to brighten up flavors.

---

*Nutritional information per tablespoon:*  
Calories 18 (24% from fat) • carb. 4g • pro. 1g • fat 1g  
• sat. fat 0g • chol. 0mg • sod. 501mg • calc. 23mg • fiber 1g

## DESSERTS/SWEET SAUCES

### COOKIE CRUST PUMPKIN PIE

*The traditional holiday favorite is made with a cookie crumb crust for a crunchy change.*

Makes 12 servings

#### **Crust:**

- ½ cup pecan halves**
- 45 vanilla wafers (may use reduced-fat wafers)**
- ½ cup unsalted butter, melted**

#### **Pumpkin Filling:**

- 2 large eggs**
- ½ cup brown sugar**
- 1 can (12 ounces) evaporated fat free milk**
- 1 can (15-16 ounces, 1½ cups) solid pack pumpkin (not pie filling)**
- 1 tablespoon cornstarch**
- ¼ cup molasses**
- 1 tablespoon vanilla extract**
- 1 teaspoon cinnamon**
- 1 teaspoon ginger**
- ¼ teaspoon freshly grated nutmeg**

Preheat the oven to 375°F.

Place the pecans in the blender jar; cover the blender jar. Set on Low and Pulse 8 to 10 times to chop finely. Remove and transfer to a 10" deep-dish pie plate. Place 15 cookies in the blender jar; cover the blender jar. Set on High and Pulse 5 times to chop the cookies, then blend for 10 seconds to pulverize; add the cookie crumbs to the nuts in the pie plate and repeat with the remaining cookies. Stir the nuts

and cookies with a fork to blend; add the melted butter and stir to combine. Press the cookie/nut mixture evenly onto the sides and bottom of the pie plate. Bake in the preheated 375°F oven for 5 minutes. Remove and let cool on a rack while continuing. Lower the oven temperature to 350°F.

Place the eggs and remaining ingredients in the blender jar in the order listed; cover the blender jar. Set on Low and blend until smooth, about 10 to 15 seconds. Pour the pumpkin mixture into the prepared cookie crust. Bake in the preheated 350°F oven for 55 to 60 minutes. Center of the pie may appear slightly jiggly – it will continue to set as the pie cools. Place the pie on a rack and cool completely before serving. Refrigerate after completely cool.

*Nutritional information per serving:*  
Calories 252 (41% from fat) • carb. 33g • pro. 5g • fat 12g  
• sat. fat 4g • chol. 42mg • sod. 117mg • calc. 129mg • fiber 2g

### CHOCOLATE CHIP OATMEAL MUFFINS

Makes 18 mini muffins

- cooking spray**
- 1 cup all-purpose flour**
- ¼ cup granulated sugar**
- 1 teaspoon baking powder**
- ¼ teaspoon salt**
- 1 large egg**
- ¼ cup unsalted butter, melted and cooled**
- ¼ cup whole milk**
- ½ teaspoon vanilla extract**
- ⅓ cup rolled oats, lightly toasted**
- ⅓ cup chopped walnuts**
- ⅓ cup semi sweet chocolate morsels**

Preheat oven to 400° F. Lightly coat mini muffin tin with cooking spray.

Place the flour, sugar, baking powder, and salt in the work bowl fitted with the chopping blade. Press the On button and combine ingredients using the high speed for 10 seconds. Remove and reserve.

---

Place the egg, butter, milk, and vanilla in the work bowl and process on high for 20 seconds. Add reserved dry ingredients and the oatmeal, walnuts, and chocolate morsels. Pulse until just combined. Scoop batter evenly into the muffin tin. Bake until puffed and golden, and a tester comes out clean, about 12-15 minutes. Transfer to a wire rack, cool slightly, serve warm.

*Nutritional information per muffin:*

*Calories 106 (48% from fat) • carb 12g • pro 2g • fat 6g  
• sat fat 2g • chol 19mg • sod 51mg • calc 10mg • fiber 1g*

## APPLE CRISP

Makes 6 servings

**cooking spray**

**¼ cup all-purpose flour**

**¼ cup light brown sugar, packed**

**7 tablespoons granulated sugar, divided**

**¼ cup unsalted butter, cut in 1/2-inch pieces**

**½ cup regular oatmeal (not quick or instant)**

**¼ cup pecan or walnut pieces**

**½ teaspoon ground cinnamon**

**3 large apples (about 1½ pounds) – Braeburn, Fuji, Golden Delicious or Granny Smith, Fuji, peeled, cored and quartered**

**¼ cup dried cranberries or raisins**

Arrange rack in lower third of oven. Preheat oven to 350°F. Lightly coat a 1¼ quart baking dish with cooking spray; reserve.

Place the flour, brown sugar, and 4 tablespoons of the granulated sugar in the work bowl fitted with the chopping blade. Press On button. Process on High for 10 seconds to combine. Add butter and Pulse on High until mixture resembles a coarse meal. Add oatmeal, nuts and cinnamon; pulse on High until the mixture resembles large crumbs, about 10 times. Press Off. Remove and reserve.

Remove the metal blade and insert the slicing disc. Press On button. Place apple quarters in feed tube. Press High to slice, using medium pressure. Transfer to a bowl and toss with remaining 3 tablespoons granulated sugar and dried cranberries. Arrange with

cream or softly whipped cream.

*Nutritional information per serving:*

*Calories 359 (35% from fat) • carb. 58g • pro. 2g • fat 15g  
• sat. fat 7g • chol. 27mg • sod. 7mg • calc. 26mg • fiber 5g*

## MINI CHIP CHEESECAKES

Makes two 4-inch cheese cakes

**cooking spray**

**2 ounces crispy oatmeal cookies or graham crackers, broken into ½-inch pieces**

**½ tablespoon unsalted butter, cut in 4 pieces**

**8 ounces lowfat cream cheese, cut in 16 pieces**

**¼ cup sugar**

**1 large egg**

**2 teaspoons vanilla extract**

**3 tablespoons semisweet mini chocolate morsels**

Preheat the oven to 350° F. Lightly coat two 4-inch (1¼ cup) springform pans with cooking spray.

Place the cookie pieces in the work bowl; press On. Press Pulse and pulse on High 5 times to break up. Add the butter and process 15-20 seconds on High until buttered crumbs are formed. Press into the bottoms of the two prepared pans. Bake in the preheated oven for 10 minutes. Place in the freezer for 5-10 minutes to cool completely. When cool, wrap each pan in a sheet of aluminum foil so that it comes at least 1 inch up the sides.

Do not wash the work bowl. Place the cream cheese and sugar in the work bowl. Process 10 seconds on High to combine. Scrape the bottom and sides of the bowl; process 15 seconds longer until smooth and creamy. Add the egg and vanilla, process on High until smooth, 20 seconds; scrape the bowl and process for another 5 seconds. Add mini morsels to work bowl. Pulse to blend in, 2-3 pulses. Divide the batter evenly between the two prepared pans. Place in a larger pan and add hot water to the depth of ½inch. Bake in the preheated oven for 25 minutes. Remove from the oven, remove foil, and place on a rack to cool completely. Cover and refrigerate at least 4 hours before serving. May be double-wrapped and frozen for up to

---

1 month. Serve plain, topped with fresh berries, or with Quick Berry Sauce.

Variation: To make Chocolate Chip Cheesecakes, add 2-3 tablespoons chocolate morsels to the batter when adding the cream cheese

*Nutritional information per serving:*  
Calories 241 (43% from fat) • carb. 30g • pro. 4g • fat 12g  
• sat. fat 6g • chol. 74mg • sod. 120mg • calc. 24mg • fiber 2g

## PEAR AND HAZELNUT CLAFOUTI

Makes 8 servings

- 3 pears, approximately 9 ounces each, peeled, cored, and quartered**
- 1½ tablespoons lemon juice**
- ½ cup blanched hazelnuts**
- ½ cup plus 1 tablespoon granulated sugar**
- ½ cup evaporated fat-free milk**
- ¾ cup melted butter**
- 2 eggs**
- 1 teaspoon vanilla extract**
- ½ cup all purpose flour**
- ¾ teaspoon baking powder**

Preheat oven to 375°. Butter a 1¼-quart baking dish.

Insert the slicing disc in the work bowl. Place the pears in the feed tube, press the On button and use the high speed feature to slice them. Toss the pears with lemon juice and arrange evenly in buttered baking dish.

Dry work bowl and insert the chopping blade. Process hazelnuts and sugar until nuts are finely ground – 15 to 20 seconds. Add the evaporated milk, melted butter, eggs, vanilla, flour and baking powder. Process for 10 seconds. Mixture will be smooth and creamy – do not over blend.

Pour the batter over the pears and sprinkle with the remaining sugar. Bake until golden brown and set, about 35 to 40 minutes.

Cool on a rack for 15 minutes before serving; serve warm with freshly whipped cream.

*Nutritional information per serving:*  
Calories 309 (60% from fat) • carb 28g • pro 4g • fat 22g  
• sat fat 10g • chol 95mg • sod 58mg • calc 82mg • fiber 3g

## QUICK BERRY SAUCE

*Serve with ice cream or cheesecake.*

Makes about 2 cups

- 12 ounces fresh or frozen, thawed strawberries or raspberries**
- ½ cup red berry preserves**
- 1 tablespoon sugar**
- 1 tablespoon fresh lemon juice**

Place all ingredients in blender jar; cover blender jar. Set on High. Blend until smooth and completely puréed, 20 to 30 seconds.

Strain mixture through a fine sieve to remove seeds; discard seeds. Store in an airtight container in refrigerator. Serve with desserts, pancakes or waffles.

*Nutritional information per serving (based on 8 servings):*  
Calories 128 (0% from fat) • carb. 33g • pro. 1g • fat 0g  
• sat. fat 0g • chol. 0mg • sod. 5mg • calc. 14mg • fiber 2g

## CHOCOLATE SAUCE

*Change the vanilla to mint for Mint Chocolate sauce.*

Makes 1¼ cups / 20 tablespoons

- 4 ounces good-quality bittersweet or semi-sweet chocolate, broken into ½" pieces**
- 4 ounces good-quality milk chocolate, broken into ½" pieces**
- 2 tablespoons sugar**
- ½ cup fat-free milk, heated until just bubbling around the edges**

---

### **1½ teaspoons vanilla**

Place the chocolates in the blender jar; cover blender jar. Set on Low. Pulse to chop the chocolates, 10 to 15 times. Add the sugar; process to chop, 20 seconds. With the blender running, remove the measured pour cup. Pour the hot milk slowly and carefully through the pour spout and blend until the chocolate is melted and smooth, 1 minute. Add the vanilla; blend to combine, 10 seconds. Serve warm or let cool; place in an airtight container and refrigerate. Reheat before serving.

*Nutritional information per serving (1 tablespoon):*

*Calories 65 (50% from fat) • carb. 8g • pro. 1g • fat 4g  
• sat. fat 2g • chol. 1g • sod. 3mg • calc. 11mg • fiber 0g*

# Cuisinart®

SAVOR THE GOOD LIFE®



Coffeemakers



Food Processors



Toaster Ovens



Wafflemakers



Cookware



Ice Cream Makers

Cuisinart offers an extensive assortment of top quality products to make life in the kitchen easier than ever. Try some of our other countertop appliances and cookware, and Savor the Good Life®.

**[www.cuisinart.com](http://www.cuisinart.com)**

©2005 Cuisinart  
Cuisinart® is a registered trademark of Cuisinart  
150 Milford Road  
East Windsor, NJ 08520  
Printed in China

04CU13243

U IB-5340ATX



Version no.: CBT500FP IB-530ATX

SIZE: 216mm(W) x 178mm(H)  
Total Pages : 32pcs

Material:  
Cover:157gsm Matt Artpaper  
Inside: 120gsm Gloss Artpaper

Coating:

Color:  
Cover: 4C + 1C  
Inside: 1C + 1C

DATE: 10/30/04

P. O.: 0410000 (00/00/2004\_OP)