

# Cuisinart™



## 7.0 QUART STAND MIXER



**RECIPE  
BOOKLET  
REVERSE  
SIDE**

For your safety and continued enjoyment of this product, always read the instruction booklet carefully before using.

### SM-70 INSTRUCTION BOOKLET

IB-6383

89280

## IMPORTANT SAFEGUARDS

When using an electrical appliance, basic safety precautions should always be followed to reduce the risk of fire, electric shock and/or injury, including the following:

1. READ ALL INSTRUCTIONS BEFORE USING.
2. Switch off and unplug before fitting or removing tools and/or attachments, after use and before cleaning.
3. Close supervision is necessary when any appliance is used by or near children. Cuisinart does not recommend the use of this appliance by children.
4. Avoid contact with moving parts and fitted attachments. Keep hands, hair, clothing, as well as spatulas and other utensils, away from beaters during operation to reduce the risk of injury to persons and/or damage to the mixer.
5. The use of attachments not recommended or sold by Cuisinart may cause fire, electric shock or injury.
6. Do not use more than one attachment at a time.
7. Do not exceed the maximum capacities listed in this use and care instruction book.
8. Do not use the stand mixer if it is damaged or if the cord is damaged. Have the stand mixer checked and serviced before resuming use.
9. When using an attachment make sure that you have read the safety instructions that come with the particular attachment.
10. Do not use outdoors.
11. Keep stainless steel bowl away from heat sources such as stovetops, ovens or microwaves.
12. To protect against the risk of electric shock do not put the power unit in water or other liquid.
13. Remove all attachments and accessories from stand mixer before washing.
14. Do not let cord hang over edge of table or counter.

## SAVE THESE INSTRUCTIONS FOR HOUSEHOLD USE ONLY

**NOTE:** The maximum rating is based on the attachment that draws the greatest power. Other recommended attachments may draw significantly less power.

### WARNING: RISK OF FIRE OR ELECTRIC SHOCK



The lightning flash with arrowhead symbol within an equilateral triangle is intended to alert the user to the presence of un-insulated dangerous voltage within the product's enclosure that may be of sufficient magnitude to constitute a risk of fire or electric shock to persons.



The exclamation point within an equilateral triangle is intended to alert the user to the presence of important operating and maintenance (servicing) instructions in the literature accompanying the appliance.

### SPECIAL CORD SET INSTRUCTIONS

A short power-supply cord is provided to reduce the risks resulting from becoming entangled in or tripping over a longer cord.

Longer extension cords are available and may be used if care is exercised in their use.

If a long extension cord is used, the marked electrical rating of the extension cord must be at least as great as the electrical rating of the appliance, and the longer cord should be arranged so that it will not drape over the countertop or tabletop where it can be pulled on by children or tripped over.

## NOTICE

This appliance has a three wire grounded plug. To reduce the risk of electric shock, this plug will fit in a polarized outlet only one way. If the plug does not fit fully in the outlet, reverse the plug. If it still does not fit, contact a qualified electrician.

Do not modify the plug in any way.

## CONTENTS

Important Safeguards.....	2
Features and Benefits .....	4
Assembly Instructions, Diagram .....	5
Operating Instructions.....	6
Cleaning and Maintenance .....	6
Suggested Speed Control Guide.....	7
Maximum Capacities.....	8
Troubleshooting.....	8
Tips and Hints .....	8
Cookie Baking .....	9
Bread Baking .....	9
Cake Baking .....	10
Whipping Cream.....	11
Optional Attachments .....	11
Warranty Information.....	12

## INTRODUCTION

This is the mixer that does it all! Your new extra-large Cuisinart™ 7 Quart Stand Mixer has the power, capacity and precision to handle any job your recipes require. With three accessories, you can mix, whip or even knead dough. With 12 speeds, you'll always do it just right. And with the auto shutoff Countdown Timer you'll always do it for just the right amount of time! Results will be perfect.

Cuisinart offers optional attachments that can be purchased separately. Each connects to one of three power outlets on the mixer to let you blend, process food, squeeze juice from your favorite citrus fruits, make perfect homemade pasta, or grind your own meats (see page 11 for details).



## FEATURES AND BENEFITS

- 1. Tilt-back Head**  
Makes it easy to attach accessories and scrape sides of bowl.
- 2. Top Cover**
- 3. High Speed Power Outlet**  
Blender and Food Processor attachments (sold separately) connect to the rear power outlet on top of the stand mixer.
- 4. Mid Speed Power Outlet**  
Citrus Juicer attachment (sold separately) connects to the front power outlet on the top of the stand mixer.
  - 4a. Mid Speed Power Outlet Plug**
- 5. Slow Speed Power Outlet**  
Large Meat Grinder and Pasta Maker attachments (sold separately) connect to the power outlet located behind the slow speed outlet cover on the front of the stand mixer head.
  - 5a. Slow Speed Outlet Cover Release Lever**
- 6. Accessory Power Port**  
Chef's whisk, flat mixing paddle, dough hook and splashguard connect to this port.
- 7. 7 Quart Stainless Steel Bowl with Handles**  
Handles make the bowl easy to hold, scrape and remove. Oversized bowl lets you mix larger quantities.
- 8. Head-lift Release Lever**  
Securely locks stand mixer head into raised tilt-back position.
- 9. On/Off, Fold and Speed Control Dial**  
12 speeds for precision mixing.
- 10. 15-Minute Countdown Timer with Auto Shutoff**  
Turns off stand mixer after selected time has elapsed.
- 11. Chef's Whisk**  
Used for incorporating air into ingredients/mixtures. Most frequently used for whipping eggs, egg whites or heavy cream. The chef's whisk would be used in recipes for angel food cake, chiffon cake, meringue or dacquoise, some types of candy such as divinity, and for whipping potatoes after they have been mashed using the flat mixing paddle.
- 12. Flat Mixing Paddle**  
Used for stirring, mixing, beating ingredients/mixtures. Most frequently used for mixing cookies, cakes, batters (use flat mixing paddle to start the batter for yeast breads then switch to dough hook for a more evenly mixed dough), and frostings. It is also used for making piecrusts, biscuits and shortcakes, dough for pasta, combining ingredients for meatloaf or meatballs, and mashing potatoes.
- 13. Dough Hook**  
Used for the final mixing and kneading of yeast doughs for breads, rolls, pizza/focaccia, and yeast-raised coffee cakes.
- 14. Splashguard with Pour Spout**  
Prevents spattering when mixing and adding ingredients.

## ASSEMBLY INSTRUCTIONS

- 1. Raise Mixer Head** – Pull up the head-lift release lever and raise the stand mixer head until it locks into place.
- 2. Attach Accessory** – Place flat mixing paddle, chef's whisk or dough hook into the accessory power port. Turn counterclockwise until it locks. Turn clockwise to remove.
- 3. Place Bowl on Base** – Turn clockwise to secure.
- 4. Lower Mixer Head** – Pull up head-lift lever again and fully lower the mixer head.
- 5. To Attach Splashguard** – Before attaching an accessory, raise stand mixer head and push the splashguard onto the rim above the accessory power port until it fully snaps into place.

**To remove:** Raise the stand mixer head and slide splashguard off rim.

**Note:** You do not need to remove splashguard to change accessories.

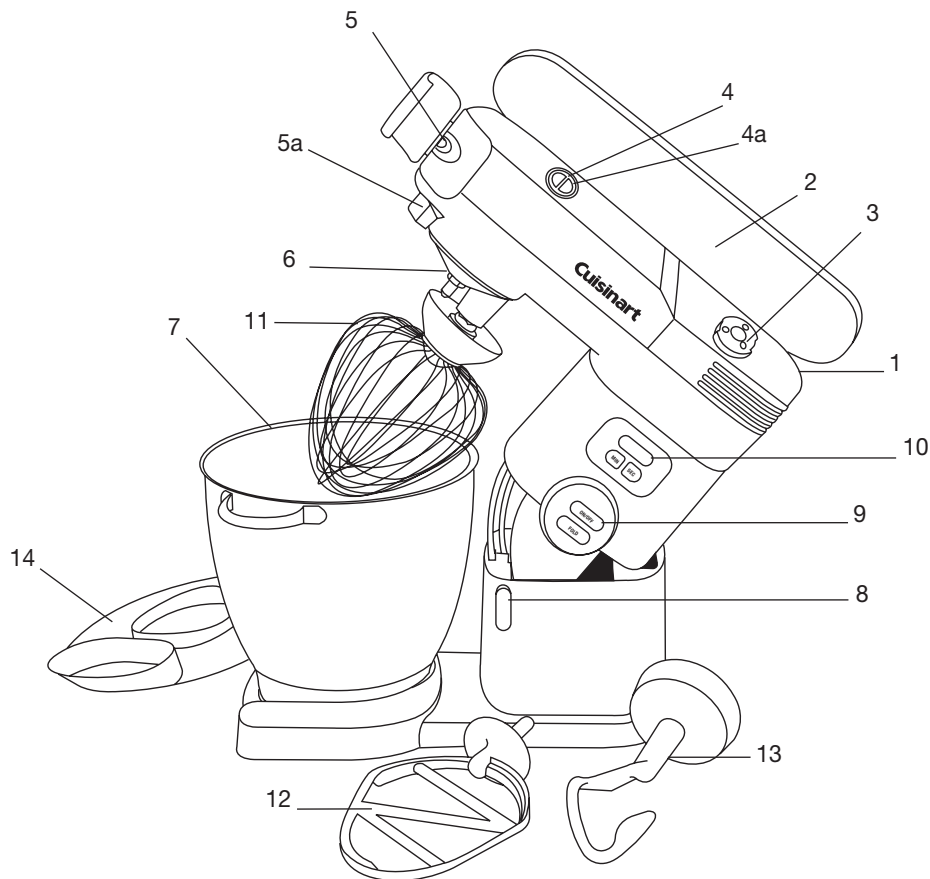

## OPERATING INSTRUCTIONS

### To Turn Stand Mixer On

1. Turn control dial to desired speed – 1 through 12 (see speed control guide on page 7).
2. Press the On/Off button in the center of the dial.

### To Turn Stand Mixer Off

1. Press the On/Off button – mixing process stops and unit shuts off.

### To Use Countdown Timer

1. **Select Speed** – Turn speed dial to desired speed.
2. **Activate Timer** – Press and hold the Minute or Second button until 00:00 begins to flash. Hold down either button to scroll through the digits, or press and release to advance one digit at a time until the desired time is displayed. Maximum time setting is 15 minutes.
3. **Begin Timed Mix** – Press the On/Off button in the center of the dial. Stand mixer starts and timer begins counting down.
4. **Automatic Shutoff** – Mixing process automatically stops when total time has elapsed. One tone signals shutoff.

### To Pause Countdown Timer

1. Press the On/Off button once to stop the stand mixer and interrupt countdown (number will flash to signify pause mode).
2. Check consistency, scrape bowl, add ingredients, etc.
3. Press the On/Off button again. The mixing process begins and the timer continues counting down the remaining time.
4. To add time during pause mode, press the Minute or Second button until the desired time is displayed.

**Safety Feature:** If there is no action on the unit after 5 minutes, the timer resets itself to “00:00”, a double tone sounds, and the unit shuts off.

### To Modify/Change Time During Use

1. Press and hold either the Minute or Second button until the current time begins to flash.
2. Unit is now in timer-set mode; use the Minute or Second button to select a new countdown setting.

### To Cancel Operation (Set back to 00:00)

1. **When unit is on** – Press and hold the On/Off button for 2 seconds. The timer resets to 00:00 and the unit shuts off.
2. **When unit is off** – Press and hold both the Minute and Second buttons for two seconds. The time will reset back to 00:00.

### To Use Fold Function

The fold operation allows you to mix in ingredients at the lowest speed.

The Fold button is located in the center of the dial.

1. **Continuous Fold** – Hold the Fold button down to blend ingredients; release to stop.
2. **Pulse Fold** – Press the Fold button repeatedly as needed to combine ingredients. Each pulse generates 1½ to 2½ revolutions of the flat mixing paddle, chef’s whisk or dough hook.

## CLEANING AND MAINTENANCE

Unplug your Cuisinart™ Stand Mixer before cleaning.

**Power Unit:** Wipe with a damp cloth and dry. Never use abrasives or immerse in water.

**Bowl:** Wash by hand and dry thoroughly or put in dishwasher. Never use a wire brush, steel wool or bleach.

**Tools:** Top rack dishwasher-safe; can also wash by hand and dry thoroughly.

**Splashguard with Pour Spout:** Top rack dishwasher-safe; can also wash by hand and dry thoroughly.

## SUGGESTED SPEED CONTROL GUIDE

<b>FOLD</b>	<ul style="list-style-type: none"> <li>• Adding ingredients at the end of mixing</li> <li>• Blending dry ingredients</li> </ul>		
<b>1</b>	<ul style="list-style-type: none"> <li>• Has the gentle start – use for stirring and starting all mixing/whipping tasks</li> <li>• Adding dry ingredients (flour) to batters and liquids to dry ingredients or batters</li> <li>• Begin creaming fats with sugars</li> <li>• Rubbing fat into flour for piecrusts, biscuits, scones</li> <li>• Begin to whip eggs or cream</li> <li>• Stirring ingredients to blend without adding air</li> <li>• Making crumb toppings</li> </ul>	<b>7</b>	<ul style="list-style-type: none"> <li>• Whipping potatoes</li> <li>• Whipping cream, cream cheese, or butter for easy spreading</li> </ul>
<b>2</b>	<ul style="list-style-type: none"> <li>• Stirring</li> <li>• Adding dry ingredients such as nuts, chocolate morsels, dried fruits</li> <li>• Creaming batters without adding air – such as cheesecake</li> <li>• Begin mashing potatoes</li> <li>• Mixing some pastry doughs</li> <li>• Mixing muffins</li> </ul>	<b>8</b>	<ul style="list-style-type: none"> <li>• Whipping cream</li> <li>• Whipping potatoes</li> <li>• Whipping egg whites – adding sugar to whipped egg whites</li> </ul>
<b>3</b>	<ul style="list-style-type: none"> <li>• Kneading yeast doughs</li> <li>• Creaming</li> <li>• Mixing batters, cookie doughs</li> <li>• Adding eggs to batter/dough</li> <li>• Mixing heavy ground meat mixtures (meatloaf, meatballs, pâté)</li> <li>• Mixing frostings</li> </ul>	<b>9</b>	<ul style="list-style-type: none"> <li>• Whipping egg whites</li> <li>• Whipping cream</li> </ul>
<b>4</b>	<ul style="list-style-type: none"> <li>• Mixing packaged cake mixes</li> <li>• Mixing batters, cookie doughs</li> <li>• Creaming to make light and fluffy</li> <li>• Adding eggs to batter/dough</li> <li>• Mixing frostings</li> </ul>	<b>10</b>	<ul style="list-style-type: none"> <li>• Whipping cream – using gradual increase from Speed 1</li> <li>• Whipping egg whites</li> <li>• Whipping butter to make compound or whipped butters</li> <li>• Mixing egg/sugars mixtures until light and fluffy</li> </ul>
<b>5</b>	<ul style="list-style-type: none"> <li>• Creaming to make light and fluffy</li> <li>• Adding eggs to creamed mixtures</li> <li>• Mixing frostings</li> </ul>	<b>11</b>	<ul style="list-style-type: none"> <li>• Whipping egg whites</li> <li>• Whipping frostings until fluffy</li> </ul>
<b>6</b>	<ul style="list-style-type: none"> <li>• Adding eggs to creamed mixtures</li> <li>• Mashing potatoes</li> <li>• Whipping egg whites until frothy</li> <li>• Beating whole egg yolks until ribbons form</li> </ul>	<b>12</b>	<ul style="list-style-type: none"> <li>• Whipping egg whites – using gradual increase from Speed 1</li> <li>• Whipping frostings until fluffy</li> </ul>

## MAXIMUM CAPACITIES FOR THE CUISINART™ STAND MIXER

7 Quart Stand Mixer	
Yeast dough (most breads, pizza)	15 cups flour
Cookie dough	15 dozen cookies
Whipping cream	8 cups
Egg whites	16

## TROUBLESHOOTING

**1. Problem:** The accessories knock against the bottom of the bowl or are not reaching the ingredients at the bottom of the bowl.

**Solution:** Adjust the height by doing the following:

- Detach the accessory.
- Hold and loosen the nut as shown.

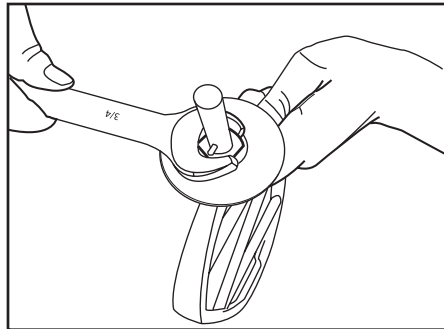

- For ideal operation, the chef's whisk and flat mixing paddle should be almost touching the bottom of the bowl.
  - Raise the stand mixer head, hold the accessory in place, and tighten.
- 2. Problem:** Your stand mixer has an overload protection device and if overloaded, it will shut down to protect the motor.

**Solution:** In the unlikely even that this happens:

- Turn off and unplug the unit.

- Reduce the load by removing some of the ingredients, and allow the mixer to stand for a few minutes.
- Plug in and reset the speed. If the stand mixer does not start when you press the on button, allow the unit to stand for additional time.

## TIPS AND HINTS

- Before preheating the oven, adjust shelves to accommodate your baking task. Pies bake best when baked in the lower third of the oven.
- Carefully follow each mixing step in a recipe. Take care not to over- or under-mix. Make use of the Countdown Timer feature of the Cuisinart™ Stand Mixer to help with suggested mixing times.
- Don't crowd the oven, and avoid opening the oven door during baking – use the oven light to help you watch. With certain recipes, particularly cookies, when baking more than one pan in the oven at a time, rotate pans halfway through the baking cycle.
- Proper measurements are very important when baking. To measure flour correctly, stir the flour first, then spoon into the measuring cup. Level off the top with the blunt side of a knife blade or the handle of a spoon. Do not press or compact flour. It is also very important not to measure directly from the bag – while the flour is pre-sifted, it has been pressed/compacted to fit into the bag. Baked goods made from unstirred flour are likely to be heavy and dry because too much flour is used.
- Remove butter from the refrigerator and cut into ½-inch pieces to help it come to room temperature faster while you measure out the remaining ingredients. Do not warm butter in the microwave; this can change the structure of the butter if it melts and give the finished product a different texture.
- To separate eggs for use in any recipe, break them one at a time into a small bowl. Gently remove the yolks, then transfer the whites to a spotlessly clean glass or stainless bowl. If a yolk breaks into a white, use that egg for another recipe. Just a drop of egg yolk in the white prevents the white from whipping properly.



- For whipping egg whites, both the mixing bowl and chef's whisk must be spotlessly clean and dry. Any trace of fat or oil will prevent the egg whites from whipping properly.
- To check the freshness of eggs, place them in a bowl of warm water – if they float, they are not fresh.
- To melt chocolate for a recipe, place chopped chocolate in a double boiler insert or larger bowl over a pan of barely simmering hot water. The water should not boil, nor should it touch the bottom of the double boiler insert or bowl. If it does, this could cause the chocolate to "seize" and you will not be able to use it in your recipe.
- Always test yeast for freshness before using it in a recipe. Sprinkle a little over warm (105-110°F) water from recipe and add a pinch of sugar or flour from the recipe. If it does not become foamy/bubbly in 5 to 10 minutes, the yeast may be "dead." Start over with fresh yeast from a new package.
- For mixing yeast doughs, begin by using the flat mixing paddle. When starting a recipe, dough is thinner and more like a batter and mixes more efficiently and smoothly with a paddle. After a very thick, smooth batter forms, switch to the dough hook to complete the recipe.

## COOKIE BAKING

- Use an ice cream scoop to measure out cookie dough – this keeps the cookies evenly shaped and uniform in size. We recommend ice cream scoops in several sizes – #'s 40, 50 and 60, as well as a larger one (about 1/3 to 1/2 cup) for jumbo cookies. Ice cream scoops, also known as "dishers" are also good for filling muffin tins. Use a #16 ice cream scoop to make muffins or meatballs.
- To better maintain cookie shapes, put scoops of cookie dough onto sheets of waxed paper or plastic wrap on a tray and chill before baking. Most cookie dough can be refrigerated for 2 to 3 days prior to baking – be sure to wrap well.
- Cookie dough may also be frozen. Shape into individual cookies, double wrap and freeze for up to 3 months.

- Line baking sheets with parchment for easy release and easy cleanup.
- Let cookies rest on sheets for 2 to 3 minutes before removing them to a wire rack to cool. This keeps cookies from wrinkling, crumbling or breaking.
- Cookies must cool completely before being put into storage containers to avoid them becoming soggy and misshapen.

## BREAD BAKING

- One 1/4-ounce packet of yeast equals 2 1/4 teaspoons yeast.
- Using milk in place of water will produce a softer crust.
- After baking, you can soften the crust, if desired, by rubbing it with unsalted butter soon after removing it from the oven. This prevents it from drying out too quickly.
- If a recipe calls for a specific type of flour, used the flour recommended. If you do not have bread flour, you can substitute unbleached, all-purpose flour, but your bread may not rise quite as much.
- Do not use "lite" or tub margarines for bread baking – the first ingredient is often water and they do not work well in any baking.
- Vital gluten is the dried protein taken from the flour by eliminating the starch. It is a good dough conditioner or enhancement for yeast breads, especially for whole grain breads or when using all-purpose flour. If a recipe specifically calls for vital gluten, we recommend that it be used for best results.
- For 100% whole wheat bread use 1 1/2 teaspoons vital gluten per cup of flour.
- Lite salt can be used if it has both potassium chloride and sodium.
- Many bread recipes have a "range" amount of flour – start by using the lower end of the range, then add more flour as needed to produce a smooth, not sticky dough.
- Before measuring molasses or honey, oil the measuring spoon to help it run off better.
- To produce a higher loaf of bread, use water that potatoes have been cooked in.

- Using too much liquid, or baking on a humid day, can cause your bread to fall or wrinkle on top.

## CAKE BAKING

- Have all ingredients and mixing bowls at room temperature (BUT when preparing whipped cream as a topping, bowl, chef's whisk, and cream should be refrigerator-cold). Room temperature ingredients incorporate and blend more easily.
- Fill pans immediately after mixing.
- Bake immediately after filling pans.
- Check for doneness at the beginning of the time range given.
- Cool cakes completely on a wire rack after baking.
- Using an offset spatula will make spreading frosting easier.

### Egg Whites

Egg whites at room temperature are best for whipping. Bring to temperature safely by placing eggs in a bowl of warm water for 10 to 15 minutes.

Add a small amount of acid such as cream of tartar, lemon juice or vinegar when whipping egg whites to stabilize them and allow them to reach their optimum volume and stiffness. Use  $\frac{1}{8}$  teaspoon cream of tartar per large egg white – or 1 teaspoon cream of tartar per cup of egg whites (8 to 10 large).

The time required to whip egg whites will vary with the temperature of the egg whites, age of egg whites, and temperature/humidity of the kitchen. Keep a close watch while whipping egg whites.

In humid or damp weather, you may not get the volume of whipped egg whites that you do in drier, warmer weather.

Place the room temperature egg whites in the clean, dry mixing bowl. Attach the clean, dry chef's whisk. Start whipping the egg whites and gradually increase to speed 6 until foamy, and then gradually increase to speed 12. If egg whites are beaten too rapidly in the beginning, their structure will not be as stable and strong, and they will not reach the volume that they should when completely beaten. Over-beaten egg whites will also separate or weep in a meringue topping.

Timing when adding sugar to egg whites is important. If adding less than  $\frac{1}{4}$  cup (4 tablespoons), add it in the beginning at the raw white stage. For larger amounts, add sugar slowly and gradually to the whipped egg whites after they reach soft peak stage. Always add sugar in a slow steady stream while egg whites are being whipped – do not add sugar directly to the center of the bowl on top of beaten egg whites; doing this may cause them to deflate.

When whipping egg whites, they will at first appear foamy or frothy. Then they will become stiffer and start to hold their shape. Next, soft peaks will form – this is when the tips of the peaks fall when the whisk is lifted up – soft peaks are often required for mousses or soufflés. The next stage is almost stiff to stiff peaks. This is used for recipes such as meringues – the whites will appear dry, the peaks will hold their shape, and the whites will be shiny. The final stage is stiff and dry. The whites will not be uniformly white, but will appear speckled, and they will no longer be shiny in appearance.

Beaten egg whites should be used immediately after beating them. If they wait for longer than 5 minutes, they will begin to deflate and lose volume and structure. Egg whites beaten with sugar or cream of tartar are more stable and will last a little longer.

### Sanitizing Egg Whites

Take care when adding raw egg whites to recipes that are not cooked or baked as there is a chance they may carry harmful bacteria. If you have a recipe that calls for raw egg whites, you may wish to use powdered egg whites or "sanitize" the egg whites by doing the following: Place the egg whites, 2 tablespoons of the granulated sugar from your recipe, 2 tablespoons water, and a pinch of cream of tartar in the Cuisinart™ mixing bowl and stir until smooth. Place over the pan of simmering water and stir constantly with a spotlessly clean rubber spatula until the mixture registers 160°F on an instant-read thermometer – start checking the temperature after about a minute of stirring. When the egg white mixture registers 160°F, dry off the bottom of the bowl and place on the Cuisinart™ stand mixer. Insert the chef's whisk. Continue as directed in your recipe.

## WHIPPING CREAM

The difference between heavy cream and whipping cream is the butterfat content. The higher the butterfat content, the more stable the whipped cream. Heavy cream has a higher butterfat content than whipping cream does. Light cream may also be whipped, but will not last as long. Creams that are not ultra-pasteurized are best for whipping.

The yield of cream generally doubles in volume. To make 2 cups of softly whipped cream, pour 1 cup of heavy/whipping cream into the well-chilled mixing bowl. Starting on speed 1 and increasing to speed 10 or 12, whip until it just begins to hold its shape. Add about ½ teaspoon pure vanilla or other pure flavored extract and 1 to 2 tablespoons granulated or superfine sugar. Whip until the cream holds soft, floppy peaks.

### To make whipped cream

- Start with well-chilled cream, mixing bowl and chef's whisk (place bowl and whisk in freezer for at least 15 minutes before making whipped cream). The room should not be too hot.
- Whip cream on low speeds until small bubbles foam – this will take about 30 seconds.
- Gradually increase to speed 6 and continue beating until the whisk leaves a trail.
- If you are making a sweetened, flavored whipped cream, begin to slowly add the sugar and flavorings as the cream becomes soft and billowy in appearance.
- Increase to speed 8 or 10 – but do not look away – it takes just seconds for cream to go from smooth and creamy whipped cream to whipped cream with grainy bits of butter forming.
- Stop whipping cream when it has doubled in volume – it should be smooth, creamy and thick, forming either soft (for garnishing desserts, folding into desserts) or stiff (for topping cakes, desserts, piping decoratively) peaks.
- Unless stabilized, whipped cream should be served immediately.

### Stabilized whipped cream

Stabilized whipped cream will hold longer in the refrigerator before using, and it can

also be used for decorating using a pastry bag and tip. Using gelatin or a purchased stabilizer will prevent whipped cream from weeping.

To make stabilized whipped cream, soften gelatin by sprinkling it over water in a measuring cup. Let stand 5 minutes to soften. Then place the measuring cup in a pan of simmering water and stir over low heat until gelatin is dissolved. Let cool slightly before adding to cream – but do not allow to get cold and harden.

- For 1 cup of cream, use ½ teaspoon gelatin soaked in 1 tablespoon water.
- For 2 cups of cream, use 1 teaspoon gelatin soaked in 2 tablespoons water.
- For 8 cups of cream, use 1 tablespoon + 1 teaspoon gelatin soaked in 8 tablespoons water.

Follow basic whipping instructions, adding cooled gelatin mixture to cream all at once after it is whipped to a slightly thickened stage.

## OPTIONAL ATTACHMENTS AND ACCESSORIES

Your Cuisinart™ Stand Mixer has three power outlets – two on the top and one on the front – for a variety of attachments that can be purchased separately.

Simplify your life, and save valuable counter space, by using your stand mixer as a power source for these versatile attachments:

**Pasta Maker** – makes delicious homemade pasta. Includes six pasta plates, from spaghetti to lasagna.

**Large Meat Grinder** – grinds a variety of meats, vegetables, and cheeses. Includes 3 grinding plates and 2 nozzles for making homemade sausage.

**40-ounce Glass Blender** – blends frozen drinks, smoothies and shakes, and even purées soups and sauces.

**Citrus Juicer** – extracts nutritious juice from all your favorite citrus fruits.

**Food Processor** – chops, purées, slices, and shreds in clear 3-cup work bowl. Includes a chopping blade and a reversible slicing/shredding disc.

## WARRANTY

### Limited Three-Year Warranty

This warranty is available to consumers only. You are a consumer if you own a Cuisinart™ Stand Mixer which was purchased at retail for personal, family or household use. Except as otherwise required under applicable law, this warranty is not available to retailers or other commercial purchasers or owners.

We warrant that your Cuisinart™ Stand Mixer will be free of defects in materials and workmanship under normal home use for 3 years from the date of original purchase.

We suggest you complete and return the enclosed product registration card promptly to facilitate verification of the date of original purchase. However, return of the product registration card does not eliminate the need for the consumer to maintain the original proof of purchase in order to obtain the warranty benefits. In the event that you do not have proof of purchase date, the purchase date for purposes of this warranty will be the date of manufacture.

If your Cuisinart™ Stand Mixer should prove to be defective within the warranty period, we will repair or, if we think necessary, replace it. To obtain warranty service, please call our Customer Service Center toll-free at 1-800-726-0190 or write to:

Cuisinart  
150 Milford Road  
East Windsor, NJ 08520

To facilitate the speed and accuracy of your return, enclose \$10.00 for shipping and handling. (California residents need only supply a proof of purchase and should call 1-800-726-0190 for shipping instructions.) Please be sure to include your return address, description of the product's defect, product serial number, and any other information pertinent to the return. Please pay by check or money order.

**NOTE:** For added protection and secure handling of any Cuisinart® product that is being returned, we recommend you use a traceable, insured delivery service. Cuisinart cannot be held responsible for in-transit damage or for packages that are not delivered to us. Lost and/or damaged products are not covered under warranty.

Your Cuisinart™ Stand Mixer has been manufactured to the strictest specifications and has been designed for use only with authorized accessories and replacement parts.

This warranty expressly excludes any defects or damages caused by accessories, replacement parts or repair service other than those authorized by Cuisinart.

This warranty does not cover any damage caused by accident, misuse, shipment or other than ordinary household use.

This warranty excludes all incidental or consequential damages. Some states do not allow the exclusion or limitation of these damages, so they may not apply to you.

#### CALIFORNIA RESIDENTS ONLY

California law provides that for In-Warranty Service, California residents have the option of returning a nonconforming product (A) to the store where it was purchased or (B) to another retail store which sells Cuisinart products of the same type. The retail store shall then, according to its preference, either repair the product, refer the consumer to an independent repair facility, replace the product, or refund the purchase price less the amount directly attributable to the consumer's prior usage of the product. If the above two options do not result in the appropriate relief to the consumer, the consumer may then take the product to an independent repair facility if service or repair can be economically accomplished. Cuisinart and not the consumer will be responsible for the reasonable cost of such service, repair, replacement, or refund for nonconforming products under warranty.

California residents may also, according to their preference, return nonconforming products directly to Cuisinart for repair or, if necessary, replacement by calling our Consumer Service Center toll-free at 800-726-0190. Cuisinart will be responsible for the cost of the repair, replacement, and shipping and handling for such nonconforming products under warranty.

#### BEFORE RETURNING YOUR CUISINART PRODUCT

Important: If the Cuisinart™ Stand Mixer is to be serviced by someone other than Cuisinart's Authorized Service Center, please remind the servicer to call our Consumer Service Center to ensure that the problem is properly diagnosed, the product serviced with the correct parts, and to ensure that the product is still under warranty.

©2006 Cuisinart  
Cuisinart® is a registered  
trademark of Cuisinart

150 Milford Road  
East Windsor, NJ 08520  
Printed in China

06CU26054