

Cuisinart®

INSTRUCTION BOOKLET

Recipe
Booklet
Reverse Side



Supreme Super 600™ Blender

SB-5600

For your safety and continued enjoyment of this product, always read the instruction book carefully before using.

G IB-6087

IMPORTANT SAFEGUARDS

When using an electrical appliance, basic safety precautions should always be followed, including the following:

1. **READ ALL INSTRUCTIONS BEFORE USING.**
2. To protect against the risk of electrical shock, do not put motor base of blender in water or other liquid.
3. Close supervision is necessary when any appliance is used by or near children.
4. Unplug from outlet when not in use, before putting on or taking off parts, and before cleaning or removing contents from blender jar.
Never put hands into the blender jar or container, or handle the blades with appliance plugged in.
5. Avoid contact with moving parts.
6. Do not operate any appliance with a damaged cord or plug or after the appliance malfunctions, or is dropped or damaged in any manner. Return appliance to nearest Cuisinart service facility for examination, repair, and/or mechanical or electrical adjustment.
7. The use of attachments, including canning or ordinary jars, not recommended or sold by Cuisinart may cause fire, electrical shock, or risk of injury to persons.
8. Do not use outdoors.
9. Do not let cord hang over edge of counter or table or touch hot surfaces.
10. **Keep hands and utensils out of jar while blending, to reduce the risk of severe injury to persons or damage to blender itself.**
A rubber or plastic spatula may be used but must be used only when the blender is turned OFF.
11. When blender is in ON mode, and LED lights are glowing, do not touch cutting assembly, interfere with blade movement, or remove blender jar cover. Accidentally touching a speed button may activate the blender.
12. **BLADES ARE SHARP. HANDLE CAREFULLY.**
13. To reduce the risk of injury, never place cutting assembly on base unless the blender jar is properly attached.

14. Always operate blender with the cover in place.
15. Never leave your blender unattended while running.
16. When blending HOT liquids, remove measured pour lid (center piece of cover) to allow steam to escape.
17. Twist on locking ring firmly. Injury can result if moving blades accidentally become exposed.
18. Do not use an extension cord with this unit. Doing so may result in fire, electrical shock, or personal injury.

Regarding your cord set: A longer cord has been provided so that you will have flexibility in positioning your Cuisinart® Supreme Super 600™ Blender near an electrical outlet. Exercise care when using the longer cord, to avoid entangling or tripping over the cord. The longer cord should be arranged so that it will not drape over the counter or tabletop, where it can be pulled on by children or tripped over. Excess cord should be stored in the cord storage area at the back of the blender base to avoid injury caused by the longer cord.

19. Wash the blender jar, cutting assembly, locking ring, and cover before first use.
20. **WARNING:** TO REDUCE THE RISK OF ELECTRICAL SHOCK OR FIRE, DO NOT REMOVE THE BASE PANEL. NO USER SERVICEABLE PARTS ARE INSIDE. REPAIR SHOULD BE DONE ONLY BY AUTHORIZED PERSONNEL.
21. **WARNING:** FLASHING LIGHT INDICATES READY TO OPERATE. DO NOT TOUCH BLADES.

SAVE THESE INSTRUCTIONS FOR HOUSEHOLD USE ONLY

NOTICE

This appliance has a polarized plug (one prong is wider than the other). To reduce the risk of electric shock, this plug will fit into a polarized outlet only one way. If the plug does not fit fully into the outlet, reverse the plug. If it still does not fit, contact a qualified electrician. Do not modify the plug in any way.

UNPACKING INSTRUCTIONS

1. Place the gift box containing your Cuisinart® Supreme Super 600™ Blender on a flat, sturdy surface before unpacking.
2. Remove instruction book and other printed materials from top of corrugated insert.
3. Remove corrugated insert containing measured pour lid.
4. Lift blender base from box.
5. Carefully lift out corrugated insert containing the glass blender jar assembly.

To assemble the blender, follow the Assembly Instructions in this booklet. Replace all corrugated inserts in the box and save the box for repackaging.

Before using for the first time: Wash all parts according to the Cleaning and Maintenance section in this booklet to remove any dust or residue.

CONTENTS

Important Safeguards	2
Unpacking Instructions.....	3
Introduction	3
Features and Benefits	4
Use and Care/Assembly	4
Helpful Reminders	5
Operation	5
Easy Reference Guides	5
Cleaning and Maintenance.....	6
Dos and Don'ts	7
Warranty Information	8

INTRODUCTION

This may be the most powerful blender you'll ever own. The secret is the high-torque 600-watt motor that powers our cyclonic blending action. Your Supreme Super 600™ Blender delivers consistently smooth results fast whether you're making delicious smoothies or healthy vegetable purées. Preprogrammed speeds take the guesswork out of blending, and dishwasher-safe parts take the effort out of cleaning!

FEATURES AND BENEFITS

1. Cover

Just press on. Tightfitting seal resists leakage.

2. 2-oz. Measured Pour Lid

Allows you to measure and add ingredients without removing the cover.

3. 60-oz. Glass Jar with Pour Spout

Has a unique, sturdy, widemouth design and a pour spout.

4. Leak-proof Rubber Gasket (not shown)

Holds the glass jar snugly in position for safe operation.

5. High-quality Cutting Assembly with Patented Stainless Steel Blades

Is strong enough for all blender tasks, including tough jobs, from ice crushing to chopping delicate herbs.

6. Locking Ring

Is self-aligning so that the glass blender jar screws easily into position.

7. Heavy-duty Motor Base

Is so sturdy and stable, it will not “walk” on your counter – even during ice crushing!

8. Preprogrammed 6-Speed Push-button Controls

Is easy to use, read and clean. The red LED lights clearly indicate what blender speed you are using.

8a. Pulse at Any Speed Button

Allows you to pulse at any speed from high to low, so you can blend ingredients only as much as needed.

8b. Ice Crush Button

This button is preset to the best speed for crushed ice.

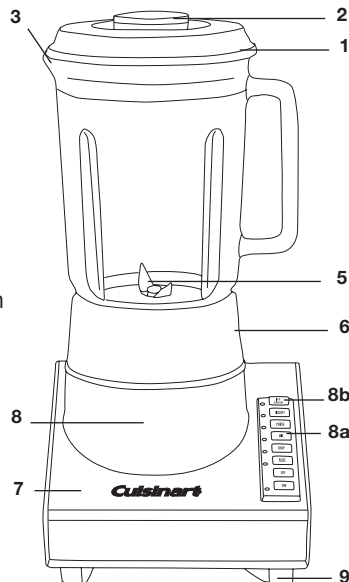

Note: Blades are sharp... handle carefully.

9. Slip-proof Feet

Prevent movement during use and prevent damaging marks on countertops or tables.

10. Cord Storage (not shown)

Keeps countertop safe and neat by storing excess cord conveniently.

USE AND CARE

ASSEMBLY

To use your Cuisinart® Supreme Super 600™ Blender, begin by assembling the blender jar.

1. Turn the blender jar (a) upside down, and place it flat on a sturdy surface.
2. Position the rubber gasket (b) on the round opening on the bottom of the blender jar.
3. Turn the cutting assembly (c) upside down, and place the blade end in the blender jar opening.

Note: Blades are sharp... handle carefully.

4. Secure the rubber gasket and cutting assembly into position by placing the smaller opening of the locking ring (d) on top of the cutting assembly. Engage threads by twisting the locking ring clockwise until tightened. Make sure locking ring is tightly fastened to blender jar. Once assembled, turn the blender jar right side up. **Note: Never place blade assembly on base unless assembled to jar.**
5. Push the cover onto the top of the blender jar. Push the measured pour lid into the cover.
6. Place the blender jar on the motor base so that the jar markings are facing you and the handle is positioned to one side.
7. Plug in power cord. Your blender is now ready to be used.

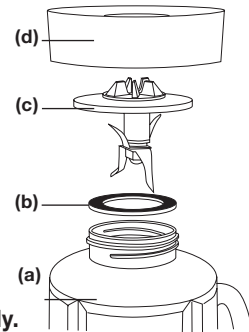

HELPFUL REMINDERS

- Once the cover is in position, additional ingredients can be added during blending by simply lifting the measured pour lid, adding ingredients, and replacing the measured pour lid.
- Cover should always be in place while the unit is on.
- **Warning:** Do not place blender jar onto base while motor is running.
- Do not twist locking ring off blender jar when removing blender jar from base. Simply lift blender jar from motor base.
- Boiling liquid or solid frozen foods (with the exception of ice cubes or ½-inch [1.3 cm] pieces of frozen fruit) should never be placed in the blender jar.
- Do not place ice, frozen foods or very cold liquids into a blender jar which has come directly from a hot dishwasher.
- Do not place very hot liquids or foods into a blender jar which has come directly from the freezer. Boiling liquids should cool for 5 minutes before being placed in blender jar.
- Follow Cleaning and Maintenance instructions on page 6 prior to your first use.

OPERATION

1. Place the motor base of your Cuisinart® Supreme Super 600™ Blender onto a flat, sturdy surface. It is important that the surface be clean and dry. Assemble the blender by following the assembly instructions. Once the jar is assembled and is in position on the motor base, plug the blender into an electrical outlet.
2. Add all necessary ingredients to the blender jar, and replace the cover. You may add more ingredients by lifting the measured pour lid and dropping ingredients through the fill area. Replace the measured pour lid after adding ingredients. **Do not place hands into blender jar with blender plugged in.**

Note: Add liquid ingredients first, then follow with solid ingredients. This will provide more consistent blending and prevent unnecessary stress on the motor.

QUICK REFERENCE GUIDE

To activate blender	Press “On” – The blender is in on mode
To begin blending	Press desired speed button
To change speeds	Press desired speed button
To pulse	In “On” mode press “Pulse”, then press and release desired speed button as needed
To crush ice	In “On” mode, press and release “Ice Crush” button as needed.
To stop blending (and deactivate blender)	Press “Off” button.
To stop blending (in pulse or ice crush mode)	Release button.
To stop blending (in chop, mix purée or liquefy mode)	Press speed button again. This will return the blender to “On” mode. Press “Off” button to turn blender off.

SPEED SELECTION GUIDE

Refer to this guide to choose the best speed for your desired result.

Ingredient	Speed	Result
Nuts	Chop	Coarse to fine
Whipping cream	Mix	Thick topping
Bread crumbs	Mix	Uniformly fine
Grating citrus zest	Purée	Uniformly fine
Milk Shakes	Purée	Smooth and creamy
Baby food	Purée	Smooth and creamy
Health drinks	Liquefy	Smooth and creamy
Frozen cocktails	Liquefy	Thick and slushy
Grinding hard cheese	Liquefy	Coarse to fine
Spices	Liquefy	Coarse to fine
Ice	Ice Crush	Snowy

Note: To remove blender jar cover, lift edge of cover upwards. Lifting measured pour lid will not remove cover.

3. **To start blending:** press the “On” button. The red “On” LED light will flash, indicating that the blender is turned on but no speed has been selected.
4. **Press the desired blending speed:** both the “On” indicator light and the activated speed indicator light will glow. The blender will now be functioning at the desired speed. It is possible to switch speeds without pressing the “Off” button, by simply pushing the next desired speed button.

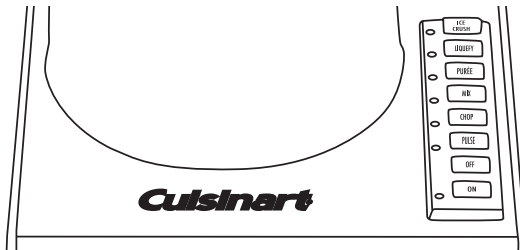

5. **To stop the blending process:** re-press the activated speed button. The blending process will stop. The red “On” indicator light will continue to flash to let you know that the blender is still on and can be reactivated by pushing the desired speed button. The blender can be completely deactivated and stopped at any speed by pushing the “Off” button. You will need to press the “On” button again to continue blending.
6. **Pulse mode:** while the blender is turned on, you can create a burst of power for quick, efficient blending, by activating the pulse function. To do so, first push the “Pulse” button, which will cause the pulse indicator light to flash. Next, push and release the desired speed button. Repeat as desired. You determine the duration of each pulse. While pulsing, all indicator lights (the on, the pulse, and the desired speed) will glow. The pulse function can be used to break apart larger pieces of food or to control the texture of food when chopping. The pulse function is also effective in starting the blending process when you do not want continuous power, or when processing items which do not require an extended amount of blending.

7. **To crush ice:** the Supreme Super 600™ Blender motor is strong enough to crush ice without liquid at any speed; however, for your convenience, we have preset the best speed for ice crushing. To give you greater control, the ice crush function automatically operates as a pulse function. To crush ice, place ice cubes in the blender jar, and place the cover and the measured pour lid on the blender jar. Press the “On” button. Press the “Ice Crush” button in short pulses until ice is crushed to desired consistency. See the Recipe Tips and Hints for more details.
8. **To dislodge food:** use a rubber or plastic spatula to help remove food lodged around the cutting assembly. **Do not use spatula until you have turned the blender off.** Replace the cover and measured pour lid and continue blending, if necessary. Make sure spatula is not inside the blender jar before blending.
9. **When finished blending:** press the “Off” button and unplug the blender from the electrical outlet. Never remove the blender jar from the motor base until the blender is off. Do not twist locking ring from blender jar when removing jar from motor base. Simply lift blender jar from motor base. **Do not place hands into blender jar with blender plugged in.**

CLEANING AND MAINTENANCE

Always unplug your Cuisinart® Supreme Super 600™ Blender from the electrical outlet before cleaning. The blender is made of corrosion-resistant parts which are easy to clean. Before first use and after every use, clean each part thoroughly. Periodically check all parts before reassembly. If any part is damaged or blender jar is chipped or cracked, DO NOT USE BLENDER.

Remove the blender jar from the motor base by lifting straight up and away. Twist off the locking ring by turning counterclockwise. Remove the cutting assembly and rubber gasket. Wash in warm soapy water, rinse, and dry thoroughly.

Place the locking ring in the upper rack of the dishwasher or wash in warm water.

CAUTION: Handle the cutting assembly carefully. It is SHARP and may cause injury. Do not attempt to remove blades from cutting assembly.

Remove the blender jar cover and the measured pour lid. Wash in warm, soapy water; rinse and dry thoroughly, or place in upper rack of dishwasher. The blender jar must be washed in warm, soapy water and rinsed and dried thoroughly. The blender jar can also be placed upside down in dishwasher.

Finally, wipe the motor base clean with a damp cloth to remove any residue, and dry thoroughly. Never submerge the motor base in water or other liquid, or place in a dishwasher.

Tip: You may wish to clean your blender cutting assembly as follows: Squirt a small amount of dishwashing liquid into assembled blender jar and fill halfway with warm water. Select Mix and run for 30 seconds, or as needed. Repeat, using clean tap water. Empty blender jar and carefully disassemble parts. Wash cutting assembly, gasket and locking ring in warm, soapy water. Rinse and dry all parts thoroughly.

DOs AND DON'Ts WHEN USING YOUR BLENDER

DO:

- Make sure the electrical outlet is rated at the same voltage as that stated on the bottom of the blender motor base.
- Always use the blender on a clean, sturdy and dry surface.
- **Always add liquid ingredients to the blender jar first, then add remaining ingredients. This will ensure that ingredients are uniformly mixed.**
- Cut most foods into approximately ½-inch (1.3 cm) to 1-inch (2.5 cm) cubes to achieve a more uniform result. Cut all cheeses into pieces no larger than ½-inch (1.3 cm).
- Use the measured pour lid to measure liquid ingredients such as alcohol. Replace measured pour lid after ingredients have been added.
- Use a rubber or plastic spatula as needed, only when the blender is turned off. Never use metal utensils, as damage may occur to the blender jar or cutting assembly.
- Place cover on firmly. Always operate the blender with the cover on.
- Make sure locking ring is tightly attached to blender jar.

- Always remove locking ring, cutting assembly, and rubber gasket before cleaning.
- When scraping the blender jar with a spatula, remove the food from the sides of the blender jar and place food in the center of the blender jar, over the cutting assembly.
- When chopping fresh herbs, garlic, onion, zest, bread crumbs, nuts, spices, etc, make sure the blender jar and cutting assembly are completely dry.
- Pulses should be short bursts. Space the pulses so the blades stop rotating between pulses. If food tends to stick to the sides of the blender jar when blending, pulse in short bursts.

DON'T:

- Don't store food or liquids in your blender jar.
- Don't place cutting assembly and locking ring onto motor base without the blender jar attached.
- Don't attempt to mash potatoes, knead heavy dough, or beat egg whites.
- Don't remove blender jar while unit is on. Keep the blender jar cover on the blender jar while blending.
- Don't twist locking ring from blender jar when removing blender jar from motor base. Simply lift blender jar from motor base.
- Don't overprocess foods. Blender will achieve most desired results in seconds, not minutes.
- Don't overload blender. If the motor stalls, turn the blender off immediately, unplug the unit, and remove a portion of the food, then continue.
- Don't use any utensil inside the blender jar while the motor is on.
- Don't use any container or accessories not recommended by Cuisinart. Doing so may result in injury.
- Don't place hands inside the blender jar when blender is plugged in.
- Don't add boiling liquids or frozen foods (except ice cubes or ½-inch pieces of frozen fruit) to glass blender jar. Boiling liquids should cool for 5 minutes before being placed in blender jar.

WARRANTY

LIMITED THREE-YEAR WARRANTY

This warranty supersedes all previous warranties on the Cuisinart® Supreme Super 600™ Blender.

This warranty is available to consumers only. You are a consumer if you own a Cuisinart® Supreme Super 600™ Blender that was purchased at retail for personal, family or household use. Except as otherwise required under applicable state law, this warranty is not available to retailers or other commercial purchasers or owners.

We warrant that your Cuisinart® Supreme Super 600™ Blender will be free of defects in material or workmanship under normal home use for three years from the date of original purchase.

If your Cuisinart® Supreme Super 600™ Blender should prove to be defective within the warranty period, we will repair it, or if we think necessary, replace it. To obtain warranty service, please call our Consumer Service Center toll-free at 1-800-726-0190 or write to: Cuisinart, 150 Milford Road, East Windsor, NJ 08520.

To facilitate the speed and accuracy of your return, please also enclose \$10.00 for shipping and handling of the product. California residents need only supply proof of purchase and should call 1-800-726-0190 for shipping instructions. Please also be sure to include a return address, description of the product defect, product serial number, and any other information pertinent to the product's return. Please pay by check or money order.

NOTE: For added protection and secure handling of any Cuisinart® product that is being returned, we recommend you use a traceable, insured delivery service. Cuisinart cannot be held responsible for in-transit damage or for packages that are not delivered to us. Lost and/or damaged products are not covered under warranty.

Your Cuisinart® Supreme Super 600™ Blender has been manufactured to strict specifications and has been designed for use with the Cuisinart® Supreme Super 600™ Blender accessories and replacement parts. These warranties expressly exclude any defects or damages caused by accessories, replacement parts or repair service other than those that have been authorized by Cuisinart.

These warranties do not cover any damage caused by accident, misuse, shipment or other than ordinary household use.

These warranties exclude all incidental or consequential damages. Some states do not allow the exclusion of or limitation of incidental or consequential damages, so the foregoing limitation may not apply to you.

CALIFORNIA RESIDENTS ONLY

California law provides that for In-Warranty Service, California residents have the option of returning a nonconforming product (A) to the store where it was purchased or (B) to another retail store which sells Cuisinart® products of the same type. The retail store shall then, according to its preference, either repair the product, refer the consumer to an independent repair facility, replace the product, or refund the purchase price less the amount directly attributable to the consumer's prior usage of the product. If the above two options do not result in the appropriate relief to the consumer, the consumer may then take the product to an independent repair facility if service or repair can be economically accomplished. Cuisinart and not the consumer will be responsible for the reasonable cost of such service, repair, replacement, or refund for nonconforming products under warranty.

California residents may also, according to their preference, return nonconforming products directly to Cuisinart for repair or, if necessary, replacement by calling our Consumer Service Center toll-free at 800-726-0190. Cuisinart will be responsible for the cost of the repair, replacement, and shipping and handling for such nonconforming products under warranty.

BEFORE RETURNING YOUR CUISINART® PRODUCT

Important: If the nonconforming product is to be serviced by someone other than Cuisinart's Authorized Service Center, please remind the servicer to call our Consumer Service center to ensure that the problem is properly diagnosed, the product serviced with the correct parts, and to ensure that the product is still under warranty.

©2006 Cuisinart
Cuisinart® is a registered
trademark of Cuisinart

150 Milford Road
East Windsor, NJ 08520
Printed in China

06CU26068

Any other trademarks or service marks referred to herein are the trademarks or service marks of their respective owners.

Recipe Booklet

SMOOTHIES, SOUPS & MORE!

Instruction
Booklet
Reverse Side



Cuisinart[®]

CUISINART[®] SUPREME SUPER 600™ BLENDER

BLENDING TIPS & HINTS

The simple recipes that follow include some old Cuisinart favorites as well as some creative combinations that are sure to please your friends and family. Thanks to the superior ice crushing power of the Cuisinart® Supreme Super 600™ Blender, you'll also be able to make delicious frozen drinks.

Chopping Nuts: Place ½ cup shelled nuts in the blender jar and cover blender. Select Chop and pulse until desired chop is achieved. Pulse fewer times for coarsely chopped nuts. For best results process small amounts, ½ cup or less.

Bread, Cookie or Cracker Crumbs: Break or cut bread, cookies or crackers into pieces ½ inch or less in size. For best bread results, use day-old bread (drier bread works best). Place bread, cookie or cracker pieces in blender jar. Select Purée and pulse to chop, then blend continuously until desired texture of crumbs is achieved. For best results process 1 cup or less at a time.

Crushing Ice: Add up to 10 standard ice cubes to the blender jar. Cover. Press the Ice Crush button, using short bursts, 10 times, or until cubes are the consistency of snow. Press STOP button. Pulse fewer times if coarsely chopped ice is desired.

Grating Fresh Citrus Zest: For best results, blender jar and cutting assembly must be clean and dry. Remove zest from fruit in strips using a vegetable peeler; use a sharp knife to remove the bitter white pith from the underside of the zest. Cut strips in half. Process no more than 8 strips at a time (zest of 1 medium lemon). Add strips and 1 or more teaspoons of sugar or coarse salt (from recipe) to the blender jar. Cover blender jar. Select Purée; blend for 15–20 seconds. Press STOP button.

Baby Food: Combine ½ cup cooked unseasoned or lightly seasoned vegetables, fruit or meat from the family meal with 3–4 tablespoons liquid (water, milk, fruit juice, broth, or cooking liquid) in the blender jar. Select Liquefy. Blend for 15–20 seconds until a smooth purée is reached. Add more liquid as necessary and process further until desired texture is reached. For “junior” type foods, select Purée and use the pulse. Always consult with your pediatrician/family physician concerning the best foods for your baby and when to introduce new foods to his/her diet.

Grinding Hard Cheese: Cut cheese into ½-inch pieces; remove all outer hard rind. Place cheese in blender jar. Select Chop or Mix.

Pulse to chop cheese, 10–12 times, and blend until desired grind is reached. For best results, grind no more than 3–4 ounces of cheese at a time.

Whipping Cream: If possible, chill blender jar and cutting assembly in refrigerator for 15 minutes. Add 1 cup heavy or whipping cream to blender jar. Cover jar. Select Stir (1-second pulses) 20–30 times until cream is thickened. (Do not overprocess – bits of butter will begin to

appear.) If desired add 1 tablespoon sugar and 1–2 teaspoons of vanilla or other flavoring. Consistency will be that of a thickened but not fluffy whipped cream and is most appropriate for topping desserts or coffee drinks.

GENERAL USAGE TIPS

- Assemble the blender completely before beginning any blending task, taking care that the gasket has been inserted to prevent leakage.
- Always take care to place lid firmly on blender container before blending.
- Always turn blender off and allow blades to stop completely before removing the lid or lifting container from blender.
- For “frozen” drinks, chill all ingredients before blending. This includes liquor, which may even be kept in the freezer if space allows.
- Keep frozen fruit (whole berries, slices, chunks or pieces of other fruits) on hand to be able to replace ice to make “frozen,” “slushy,” or “smoothie” type drinks at any time. Using frozen fruit keeps the drink from tasting watered down.
- Additional ice cubes or pieces of frozen fruit can be added through the feeder hole in the lid of the blender while the blender is running.
- For best results, cut foods into similar sized pieces, ½–¾ inches in size.
- If foods do not seem to be blending smoothly, use the pulse to chop, then blend continuously.
- Allow hot foods to cool slightly before blending.
- When using the Cuisinart® Supreme Super 600™ Blender to purée hot mixtures such as creamed soups and baby foods, strain the solids from the liquid, reserving the cooking liquid. Then place the cooked solids in the blender jar along with ½ to 1 cup of the reserved cooking liquid. Use the Pulse to chop, then blend until desired consistency/purée is reached. Blending hot mixtures is often better done in several batches.
- When blending hot foods/liquids, leave the feeder cap off or ajar to allow steam to be released to prevent the lid from popping up/off. Cover the lid with a clean dish towel and hold down to prevent it from lifting up.
- When blending hot foods/liquids, make certain there is sufficient room for expansion during blending.
- The blender is a perfect tool for creating baby foods and purées for special needs diets.
- A quick way to clean the blender is to let it clean itself. Add about 2 cups of warm water and a drop of liquid dish soap to the blender jar. Run the blender for about 30 seconds, until it is clean. Rinse thoroughly with warm water to remove all soap and allow to air dry.
- Xanthan gum may be added to dressings and marinades to prevent separation.

RECIPES

Before starting any of these or your own recipes, make sure the Cuisinart® Supreme Super 600™ Blender is properly assembled. Follow the assembly directions on page 4 of this instruction booklet for correct blender assembly procedure.

Nutritional information is based on number of servings indicated. If a recipe produces a range of servings, it is based on the highest serving yield for that particular recipe. If a recipe has a lower fat option, that is the one used for nutritional analysis.

DRINKS

Fresh Fruit Smoothie

Layers of fresh fruit blend in just seconds to make this all-fruit smoothie.

Makes six 8-ounce servings

- ½ **cup orange juice**
- 1½ **cups cantaloupe, cut into 1-inch pieces**
- 1 **medium banana, cut into ½-inch slices**
- ¾ **cup pineapple chunks (1-inch pieces)
(fresh or canned, drained)**
- 1 **cup navel orange segments, cut into 1-inch pieces**
- 1 **cup strawberries, hulled and halved**
- 1 **cup mango chunks (1-inch pieces)**
- 1 **cup raspberries (fresh or frozen)**
- 1 **cup blueberries (fresh or frozen)**
- 1 **cup ice cubes (about 6 standard)**

Layer the ingredients in the blender jar in the order listed. Place cover on blender jar. Blend on Liquefy and process for about 25 to 30 seconds until smooth.

Note: The riper the fruit, the sweeter the smoothie.

Nutritional information per 8-ounce serving:
Calories 138 (5% from fat) • carb. 33g • pro. 2g • fat 1g • sat. fat 0g
• chol. 0mg • sod. 9mg • calc. 41mg • fiber 6g

In the Pink Good Morning Smoothie

Fruit smoothies are a great way for non-breakfast eaters to start the day – this one is full of vitamins and antioxidants as well as flavor.

Makes 48 ounces (six 1-cup servings)

- 3 **small bananas (about 12 ounces), peeled, cut into ¾-inch pieces**
- 2 **cups fresh pink grapefruit sections
(remove and discard seeds and bitter white pith)**
- ¾ **cup pomegranate juice***
- ¾ **cup fat free or lowfat vanilla yogurt**
- 8 **ounces frozen strawberries (about 20)**

Place ingredients in blender jar in order listed. Pulse on Liquefy five times. Blend on Liquefy for 20 to 30 seconds until smooth and homogenous. Serve immediately or cover and refrigerate.

Nutritional information per 1-cup serving:
Calories 130 (5% from fat) • carb. 31g • pro. 3g • fat 1g • sat. fat 0g
• chol. 1mg • sod. 26mg • calc. 70mg • fiber 3g

*You may use either freshly made pomegranate juice or purchased pomegranate juice. To prepare fresh pomegranate juice in your Cuisinart® Supreme Super 600™ Blender, remove the seeds from a fresh pomegranate. Place them in blender jar. Select Purée and blend until puréed. Press purée through a fine mesh strainer to remove seed particles. One average pomegranate will yield about ½ cup fresh pomegranate juice.

Breakfast Banana Berry Smoothie

This meal in a smoothie is a perfect start to the day.

Makes 3-½ cups

- 1 **frozen banana**
- 1 **cup fresh strawberries**
- 1 **cup frozen berries (raspberry or strawberry)**
- 1½ **cups orange juice or soy milk**
- ½ **cup fat free vanilla yogurt**
- 1 **tablespoon protein powder (soy or whey)**

Place ingredients in the blender jar in the order listed. Place cover on blender jar. Blend on Liquefy and process for about 25 to 30 seconds until smooth.

Nutritional information per ½-cup serving:
Calories 70 (5% from fat) • carb. 12g • pro. 5g • fat 0g
• sat. fat 0g • chol. 0mg • sod. 11mg • calc. 79mg • fiber 2g

Berry, Pear & Ginger Smoothie

Ginger adds a refreshing and different flavor to this smoothie.

Makes about 6 cups

- ¾ cup cranberry juice**
- ¾ cup pear nectar**
- 2 pears, ripe but firm (about 1 pound total), peeled, cored, cut into 1-inch pieces**
- 1 cup lowfat vanilla yogurt**
- ¾ cup frozen raspberries (or blueberries)**
- ½ teaspoon ginger (or ½ tablespoon candied ginger)**
- 8 ice cubes**

Garnish: fresh raspberries, mint leaves

Place all ingredients in blender jar in order listed. Blend on Liquefy for 30 to 35 seconds, until smooth, creamy and completely emulsified.

Serve garnished with fresh raspberries and mint leaves.

Nutritional information per 1-cup serving:
Calories 129 (5% from fat) • carb. 22g • pro. 2g • fat 1g
• sat. fat 0g • chol. 2mg • sod. 29mg • calc. 82mg • fiber 3g

Mango Peach Citrus Frosty

Using frozen peaches keeps the flavors of this frosty drink intense.

Makes 5 cups

- 2 cups fresh tangerine or orange sections (remove bitter white pith and seeds)**
- 2½ cups (1 pound) mango pieces (¾-inch)**
- 8 ounces frozen sliced peaches**
- ⅓ cup juice (white grape, orange) or ginger ale***

Optional garnishes: orange or kiwi slices, a sprig of fresh mint

Place all the ingredients in the blender jar in the order listed. Blend on Liquefy until completely smooth, thick and homogenous, about 20 to 30 seconds. Serve immediately. Garnish as desired.

*Turn this into a frosty cocktail by substituting vodka or rum for the juice.

Nutritional information per ½-cup serving:
Calories 67 (5% from fat) • carb. 17g • pro. 1g • fat 0g
• sat. fat 0g • chol. 0mg • sod. 1mg • calc. 21mg • fiber 2g

Lemony Pineapple Slushy

Not too tart, not too sweet, just refreshing.

Makes about 5 cups

- 2 cups lemon sorbet**
- 2 cups fresh pineapple cubes (about 1-inch)**
- 1 banana, sliced (may freeze slices)**
- 6 ounces white grape juice or ginger ale***

Garnish suggestions: Slices/wedges of fresh pineapple, sliced fresh strawberries

Place all the ingredients in the blender jar in the order listed. Blend on Liquefy until completely smooth, thick and homogenous, about 20 to 30 seconds. Serve immediately. Garnish as desired.

For an adult drink, add rum or vodka to taste or as a replacement for the juice or soda.

Nutritional information per 1-cup serving:
Calories 210 (0% from fat) • carb. 55g • pro. 1g • fat 0g
• sat. fat 0g • chol. 0mg • sod. 15mg • calc. 21mg • fiber 1g

Dulce de Leche Shake

The popular South American caramel spread is used to flavor this delicious shake.

Makes about 6 cups

- 3 cups vanilla bean or French vanilla ice cream**
- 1½ cups milk (whole or reduced fat)***
- ⅓ cup dulce de leche (a very thick, Spanish/South American caramel sauce which can be found in well-stocked grocery and specialty food markets)**

Garnish: Sugared pecans, sliced fresh peach or strawberry

Place all the ingredients in the blender jar in the order listed. Blend on Liquefy until completely smooth, thick and homogenous, about 20 to 30 seconds. Serve immediately.

Serve in chilled martini glasses as a dessert drink. Garnish with chopped sugared pecans and a slice of fresh peach or strawberry.

*For an adult dessert drink, in addition to the milk add bourbon, rum, brandy or liqueur such as amaretto or Frangelico® – about ½ ounce per ¾-cup shake.

Nutritional information per 1-cup serving:
Calories 262 (48% from fat) • carb. 29g • pro. 5g • fat 14g
• sat. fat 8g • chol. 48mg • sod. 114mg • calc. 186mg • fiber 0g

Strawberry Shake

This shake really tastes like strawberries!

Makes about 6 cups

- 1 cup milk**
- 16 ounces frozen strawberries, thawed**
- 1 cup strawberry ice cream**
- 2 cups vanilla ice cream**

Place milk and thawed strawberries in blender jar. Cover blender jar. Blend on Liquefy until homogenous 20 seconds. Add the strawberry and vanilla ice creams. Pulse on Liquefy about 3 to 4 times, and then blend again on Liquefy until smooth, about 40 seconds. Serve immediately.

Nutritional information per 1-cup serving:
Calories 179 (36% from fat) • carb. 26g • pro. 4g • fat 7g
• sat. fat 3g • chol. 29mg • sod. 74mg • calc. 147mg • fiber 2g

Maple Almond Vanilla Shake

Maple syrup and a touch of almond perk up the traditional vanilla shake.

Makes about 6 cups

- 2 cups milk (can use lowfat)**
- 4 cups vanilla ice cream**
- 5 tablespoons pure maple syrup**
- 1 teaspoon pure almond extract**

Place all the ingredients in the blender jar in the order listed. Blend on Liquefy until completely smooth, thick and homogenous, about 20 to 30 seconds. Serve immediately.

Nutritional information per 1-cup serving:
Calories 261 (38% from fat) • carb. 36g • pro. 6g • fat 11g
• sat. fat 7g • chol. 46mg • sod. 120mg • calc. 233mg • fiber 0g

Strawberry Margarita

Using frozen strawberries instead of ice prevents this drink from having a watered down flavor.

Makes 4 cups

- 6 tablespoons fresh lime juice**
- ½ cup orange juice**
- ¼ cup Triple Sec**

- ½ cup tequila**
- 2 cups frozen strawberries**
- 1 cup strawberry sorbet**

Place ingredients in blender jar in order listed. Place cover on blender jar. Blend on Liquefy and process for about 25 to 30 seconds until smooth.

Nutritional information per 1-cup serving:
Calories 281 (1% from fat) • carb. 46g • pro. 1g • fat 0g
• sat. fat 0g • chol. 0mg • sod. 8mg • calc. 24mg • fiber 3g

Sunshine Colada

A play on the traditional piña colada – we have added mango, peaches and banana for variety.

Makes 5 cups

- 1½ cups orange-peach-mango juice (orange juice may be substituted)**
- 5 ounces dark rum**
- 2 cups fresh pineapple, cut into 1-inch pieces**
- 1 mango, cut into cubes (about 1½ cups)**
- 1 cup frozen peaches, cut into 1-inch pieces**
- 1 banana, cut into 1-inch pieces**
- ¼ cup cream of coconut**

Place ingredients in blender jar in order listed. Place cover on blender jar. Blend on Liquefy for about 25 to 30 seconds until smooth.

Nutritional information per 1-cup serving:
Calories 217 (13% from fat) • carb. 32g • pro. 2g • fat 3g
• sat. fat 2g • chol. 0mg • sod. 10mg • calc. 17mg • fiber 3g

Grasshoppers

Serve Grasshoppers as an after-dinner treat. For a non-alcoholic version, use mint and clear chocolate syrups found in coffee bars.

Makes about 3 cups – 6 servings

- 2 cups vanilla ice cream**
- ¼ cup heavy cream**
- 4 ounces green crème de menthe**
- 4 ounces white crème de cacao**
- 6 ice cubes**

Garnish: Fresh mint leaves, chocolate cookies, mini chocolate morsels

Place ingredients in blender jar in order listed. Place cover on blender jar. Blend on Liquefy and process for about 25 to 30 seconds until smooth.

Garnish and serve in chilled martini glasses.

Nutritional information per ½-cup serving:

*Calories 369 (38% from fat) • carb. 38g • pro. 2g • fat 16g
• sat. fat 10g • chol. 58mg • sod. 63mg • calc. 84mg • fiber 0g*

White Russian

A deliciously creamy dessert drink for adults.

Makes 6 cups

- 2 cups whole milk (may use lowfat)**
- ½ cup Kahlua® or other coffee-flavored liqueur**
- ½ cup vodka, preferably vanilla-flavored**
- 3 cups vanilla ice cream**

Place ingredients in blender jar in order listed. Place cover on blender jar. Blend on Liquefy and process for about 25 to 30 seconds until smooth and creamy.

Nutritional information per 1-cup serving:

*Calories 307 (29% from fat) • carb. 31g • pro. 5g • fat 10g
• sat. fat 6g • chol. 41mg • sod. 100mg • calc. 185mg • fiber 0g*

SOUPS

Cool, Creamy Avocado and Cucumber Soup

This chilled soup requires no cooking and is perfect for a hot summer day.

Makes 6 cups

- 1 medium-large cucumber, peeled, seeded, and cut into ½-inch pieces**
- 3 medium avocados (7-8 ounces each), peeled, seeded, and cut into ¾-inch pieces**
- 2 ounces chopped shallots (about 6 tablespoons)**
- 1 medium jalapeño pepper, stemmed, seeded, and cut into ½-inch pieces**
- 2½ cups buttermilk**
- ¾ cup chicken or vegetable stock (cool)**
- 3 tablespoons fresh lime juice**
- ½-1 teaspoon kosher salt (to taste)**

- ¼ teaspoon ground coriander**
- ¼ teaspoon ground cumin**
- ¼ teaspoon ground white pepper**

Place all ingredients in the blender jar in the order listed. Blend on Purée for 35 to 45 seconds until smooth, creamy and homogenous. Chill if not serving immediately.

Serving suggestions – garnish with diced tomato, chopped jalapeño peppers and slices of avocado.

Nutritional information per ½-cup serving:

*Calories 119 (65% from fat) • carb. 8g • pro. 3g • fat 9g
• sat. fat 2g • chol. 2mg • sod. 182mg • calc. 72mg • fiber 3g*

Chipotle Roasted Tomato Soup

This slightly spicy, slightly smoky tomato soup would be great with a grilled cheese sandwich.

Makes 6 cups

- 1 can (35 ounces) plum tomatoes in heavy sauce**
- 2 tablespoons extra virgin olive oil, divided**
- 1 tablespoon unsalted butter**
- 1 cup chopped (½-inch pieces) onion**
- ½ cup sliced carrots (½-inch thick)**
- ¼ cup sliced celery (½-inch thick)**
- 1 teaspoon oregano**
- ½ teaspoon ground coriander**
- ½ teaspoon ground cumin**
- 2½ cups chicken stock**
- ¼ cup white rice**
- 1 teaspoon kosher salt**
- 1-2 teaspoons chipotle peppers with sauce (from a can)**

Preheat oven to 300°F. Line a baking sheet with sides with parchment. Drain tomatoes and reserve sauce. Cut tomatoes in half lengthwise and place cut side up in a single layer on prepared baking sheet. Drizzle with 1 tablespoon olive oil and roast for 1½ hours.

Place butter and remaining olive oil in a large saucepan. Heat on medium-high until butter is melted. Add onions, carrots, and celery. Reduce heat to low and cook until vegetables are softened and translucent, about 4 to 5 minutes. Add oregano, coriander and cumin. Cook for 2 to 3 minutes until herbs are aromatic. Add reserved tomato liquid, roasted tomato halves, chicken stock, rice, and salt. Bring to a boil, then reduce heat to low and simmer, loosely covered, for 20 minutes.

Strain the solids from the cooking liquid, reserving liquid. Place solids and 1 cup of the cooking liquid in the blender jar with the chipotle peppers. Cover and blend on Purée for 20 to 30 seconds until completely emulsified, smooth and homogenous. Return purée to clean saucepan and stir in reserved cooking liquid. Reheat if necessary.

Note: Recipe may be doubled – blend to purée in 2 batches.

Nutritional information per 1-cup serving:
Calories 212 (45% from fat) • carb. 26g • pro. 5g • fat 11g
• sat. fat 3g • chol. 5mg • sod. 973mg • calc. 60mg • fiber 4g

Creamy Mushroom Soup with Roasted Mushroom “Croutons”

Porcini mushrooms add extra flavor to the soup, and the Roasted Mushroom “Croutons” make a flavorful garnish.

Makes 8 cups

For the Roasted Mushroom “Croutons”

2 tablespoons extra virgin olive oil
1 pound sliced mushrooms
1 teaspoon kosher salt

For the Creamy Mushroom Soup

2 ounces dried porcini mushrooms
2 cups boiling water
4 tablespoons unsalted butter
2 cups sliced leeks (½-inch thick)
1 cup chopped onion (½-inch pieces)
½ cup sliced celery (½-inch thick)
2 cloves garlic, peeled, smashed and cut in half
1 pound sliced mushrooms
1 teaspoon thyme
⅓ cup dry sherry
3 to 4 cups chicken stock or broth
8 ounces russet potato, peeled and cut into 1-inch pieces
1 teaspoon kosher salt
¼ teaspoon ground white pepper
2 tablespoons fresh lemon juice
¼ cup half-and-half or light cream

Preheat oven to 400°F. Line a baking sheet with parchment and drizzle with half the olive oil. Arrange the mushrooms in a single layer, drizzle with remaining olive oil and sprinkle with salt. Toss to coat, then arrange in a single layer again. Place in preheated oven and roast until

mushrooms are browned, crispy and about half their original size. Let cool and reserve to use as “croutons” for the soup.

Place the dried mushrooms in a heatproof bowl. Cover with boiling water and let stand until softened, about 20 to 30 minutes. Drain, reserving the soaking liquid. Pour the soaking liquid through a coffee filter set in a strainer to remove any impurities and reserve.

Heat the butter in a 5-quart Dutch oven type pan over medium heat. Add the leeks, onion, celery, and garlic. Cook until tender and translucent, about 3 to 5 minutes. Add the sliced mushrooms and thyme. Cook over medium-low heat until mushrooms are tender and have given up most of their liquid, about 15 to 20 minutes. Stir in the sherry and cook until reduced to about 1 tablespoon. Add enough chicken stock to the reserve mushroom soaking liquid to make 5 cups and add to the vegetable mixture with the potato and salt. Cover loosely and bring to a boil. Reduce heat to low, and simmer, loosely covered until potato is tender, about 20 minutes. Stir in pepper and lemon juice. Let stand 5 minutes. Strain the solids from the liquid, reserving all liquid. Have a large clean saucepan ready.

Place half the solids in the blender jar with 1½ cups of the liquid. Cover and blend on Purée until smooth, creamy and homogenous, about 30 to 40 seconds. Transfer to the clean saucepan and repeat with remaining solids and 1½ cups of the liquid. Combine with puréed mixture in saucepan. Stir in any remaining liquid, and half-and-half or light cream. Place over low heat to reheat to serving temperature. Serve hot and sprinkle with Roasted Mushroom Croutons.

Nutritional information per 1-cup serving:
Calories 206 (44% from fat) • carb. 23 • pro. 6g • fat 11g
• sat. fat 5g • chol. 18mg • sod. 715mg • calc. 47mg • fiber 4g

Roasted Beet & Tomato Soup with Tarragon

This is a “slow food” soup. It takes a while, but roasting the beets and tomatoes concentrates the flavors and color in this vivid ruby red soup that is scented with just a hint of tarragon. This soup may be served hot or chilled – add a dollop of sour cream or a drizzle of heavy cream if you are feeling indulgent.

Makes 8 cups

2 pounds red beets, stems cut to 3 inches in length,
greens reserved for another use or discarded
1 can (35 ounces) Italian plum tomatoes, drained,
juices reserved
2 tablespoons unsalted butter
2 cups chopped (½-inch pieces) onions

- ½ cup sliced (½-inch thick) celery
- 3 cloves garlic, peeled and halved lengthwise
- 1½ teaspoons tarragon
- 4 ounces russet potato, peeled and cubed (¾-inch cubes)
- 4-5 cups chicken stock or broth
- 1 teaspoon kosher salt
- ¼ teaspoon freshly ground white pepper

Optional garnishes: Sour cream or heavy cream, sprigs of fresh tarragon

Preheat oven to 425°F. Scrub the beets and wrap in a double thickness of aluminum foil. Place in hot oven and roast until tender when tested with a knife, about 2 to 2½ hours, depending on the size of the beets. Preheat a second oven to 300°F. Line a jelly-roll pan with parchment. Cut tomatoes in half lengthwise and arrange in a single layer on the prepared pan. Roast tomatoes for 1 hour.

Melt butter in a 5- or 6-quart Dutch oven style stockpot over medium heat. When melted, add onions, celery, and garlic. Cook, stirring frequently, until translucent, about 3 to 5 minutes. Stir in tarragon, reduce heat to low, cover loosely and cook for 10 minutes. Add the reserved tomato juices and enough chicken stock to make 6 cups of liquid in total and the cubed potato. Raise the heat to high and bring to a boil. Reduce heat to low, cover loosely and simmer for 1 hour. Stir in salt and pepper. Remove from heat and let stand 5 minutes.

Strain the solids from the liquid, and transfer all but 2 cups of the cooking liquid to a clean pot. Place half the cooked vegetables in the blender jar with 1 cup of the cooking liquid. Blend on Purée until smooth and homogenous, about 25 to 30 seconds. Transfer to the pot of cooking liquid and stir. Repeat with the remaining vegetables and cup of cooking liquid. Add to soup in pot and stir to blend. Serve hot or chilled. If serving hot, keep warm over low heat until ready to serve. Garnish as desired.

Nutritional information per 1-cup serving:
 Calories 146 (21% from fat) • carb. 24g • pro. 6g • fat 4g
 • sat. fat 2g • chol. 8mg • sod. 772mg • calc. 65mg • fiber 6g

Curried Butternut Squash & Apple Soup

A delicious autumn or winter soup – this one is a perfect first course for a holiday dinner.

Makes approximately 10 cups of soup

- 2 tablespoons unsalted butter
- 1½ cups chopped onions
- ⅓ cup thinly sliced celery (approximately 1 medium stalk)
- 2 teaspoons curry powder

- ¼ teaspoon ginger
- 2 pounds 1-inch butternut squash cubes (weigh after peeling, seeding and cubing)
- 12 ounces apples, peeled, cored and cut in wedges
- 3 tablespoons white rice
- 5 cups chicken stock
- 1 teaspoon kosher salt
- ½ teaspoon freshly ground pepper

Garnish: chopped sugared nuts and minced apple

Melt the butter over medium heat in a 6-quart sauté pan. Add the onions and celery, and cook for 2 to 3 minutes, until the vegetables are translucent. Add the curry powder and ginger, cooking for 5 to 6 minutes longer over low heat until the vegetables are softened and the spices are fragrant. Add the butternut squash, apples, and rice. Stir to coat with the butter and spices and cook for about 1 minute. Add the chicken stock, salt, and pepper. Bring soup to a boil and then reduce to simmer. Simmer for about 40 to 45 minutes, until vegetables are very tender.

Strain the solids from the liquid, reserving all liquid. Have a large clean saucepan ready.

Place half the solids in blender with 1½ cups of the liquid. Cover and blend on Purée until smooth, creamy and homogenous, about 30 seconds. Transfer to the clean saucepan and repeat with remaining solids and liquid.

Nutritional information per 1-cup serving:
 Calories 104 (21% from fat) • carb. 21g • pro. 2g • fat 3g
 • sat. fat 1g • chol. 6mg • sod. 142mg • calc. 55mg • fiber 3g

Creamy Potato Leek Soup

This versatile soup may be served hot or chilled.

Makes six servings

- 2 medium leeks, white and tender green only, sliced horizontally and cut into ½-inch pieces
- 1 tablespoon unsalted butter
- 1 small onion (3-4 ounces), peeled and cut into ½-inch pieces
- ¼ teaspoon thyme
- 2 medium russet potatoes (about ¾ pound total), peeled, cut into 1-inch slices
- 1½ cups fat free, low-sodium chicken stock or broth
- ¾ cup water
- 1 teaspoon kosher salt

½ **teaspoon white pepper**
¾ **cup half-and-half**

Place leeks in a medium bowl and add cold water. Swirl, then let stand for minutes. Lift leeks from the water without disturbing the sand/sediment collected in the bowl; allow to drain completely.

Melt butter in a large (4-quart) saucepan over medium heat. Add the drained leeks, onion, and thyme. Let cook until vegetables are softened, 3 to 5 minutes – do not brown. Add potatoes, stock, and water; cover and bring to a boil over medium high heat. Reduce heat to low, and simmer, uncovered, until potatoes are soft, about 10 to 15 minutes.

Drain vegetables, reserving cooking liquid. Place vegetables in blender jar. Add 1 cup cooking liquid; return remaining cooking liquid to saucepan. Cover blender jar. Blend on Purée until totally smooth, about 30 to 40 seconds. Stir vegetable purée into stock in saucepan and reheat over medium low heat. Add salt, pepper and half-and-half. Serve hot, or chill and serve as vichyssoise.

Nutritional information per 1-cup serving:

*Calories 132(37% from fat) • carb. 18g • pro. 3g • fat 6g
• sat. fat 3g • chol. 16mg • sod. 369mg • calc. 56mg • fiber 3g*

SAUCES, DRESSINGS, MARINADES

Romesco Sauce

This sauce of Spanish origin is delicious served with grilled chicken, vegetables, or even grilled seafood.

Makes 3½ cups sauce

5 **tablespoons extra virgin olive oil**
2 **pounds tomatoes, sliced in half**
12 **ounces sweet red peppers sliced in half**
2 **shallots, unpeeled**
5 **garlic cloves, unpeeled**
1½ **cups white bread cubed (about 1-inch cubes)**
½ **cup roasted almonds, chopped**
3 **tablespoons sherry vinegar**
3 **tablespoons sherry**
1 **cup chicken or vegetable stock**
¾ **teaspoon paprika**
¾ **teaspoon kosher salt**
fresh ground pepper

Preheat oven to 400°F.

Lightly coat a baking sheet with 2 tablespoons of olive oil and place the tomatoes, peppers, shallots, and garlic cloves on it. Roast for about 35 to 40 minutes until all vegetables are browned and soft. Place them in a bowl and cover tightly with plastic wrap. Let vegetables cool and steam to loosen skins, about 25 minutes. Once cool, peel the skins off vegetables, remove and discard seeds. Roughly chop. Reserve.

When the vegetables are almost cool, heat remaining 2 tablespoons of olive oil in a 3-quart sauté pan over medium heat. Add bread cubes and toss in oil to toast until slightly golden, about 3 minutes. Stir in almonds. Stir in tomatoes, peppers, shallot, and garlic and cook for about another 2 minutes. Add the sherry vinegar and the sherry, scraping up any bits that are stuck to the bottom of the pan. Reduce liquid by half. Add the stock and paprika and bring to a boil. Reduce to simmer for about 10 minutes. Stir in salt and pepper to taste.

Place contents of pan into the blender jar. Secure the lid tightly with a dishtowel and your hand. Blend on Purée for 40 seconds. Serve immediately or place in resealable container and refrigerate for up to one week.

Nutritional information per ½-cup serving:

*Calories 127 (67% from fat) • carb. 9g • pro. 2g • fat 10g
• sat. fat 1g • chol. 0mg • sod. 213mg • calc. 40mg • fiber 2g*

Mole Sauce

This traditional Mexican dark reddish-brown sauce is most often served with poultry, but is also delicious with pork.

Makes 4 cups

2 **tablespoons olive oil**
1 **medium onion (about 5 ounces), diced**
3 **cloves garlic, chopped**
2 **tablespoons chili powder**
¼ **teaspoon cinnamon**
¼ **teaspoon cumin**
¼ **teaspoon ground coriander**
1 **teaspoon kosher salt**
1 **corn tortilla, cut into small pieces**
¼ **cup toasted almonds**
2 **tablespoons natural peanut butter**
2 **cans (4.5 ounces each) chopped green chiles**
1 **can (28 ounces) diced tomatoes, liquid drained**
1¼ **cups chicken broth**

- ¼ **cup raisins**
- 1 teaspoon granulated sugar**
- 2 tablespoons unsweetened cocoa**

Heat the olive oil in a 3½-quart sauté pan over medium heat. Add the diced onions and sauté gently until the onions are soft and translucent, about 5 to 8 minutes. Turn heat to low and add chopped garlic, stir until coated with oil and fragrant. Add the chili powder, cinnamon, cumin, coriander, and salt. Stir until the spices are well distributed and the onions and garlic are coated, about 1 minute.

Stir in the chopped tortilla and almonds. Stir in the peanut butter. Add the green chiles, diced tomatoes, chicken stock, raisins, sugar, and cocoa. Stir and allow to simmer over low heat for about 45 minutes.

Place all ingredients in the blender jar. Blend on Purée for about 40 seconds until completely homogenous. Use immediately or keep in refrigerator in an airtight container for up to one week.

Use Mole Sauce with cooked (sautéed or grilled) chicken or shrimps, or add leftover shredded turkey or chicken to Mole Sauce, heat through, and serve over rice with garnishes of diced avocado and shredded Monterey Jack cheese.

*Nutritional information per 1/5-cup serving:
Calories 113 (49% from fat) • carb. 12g • pro. 3g • fat 7g
• sat. fat 1g • chol. 0mg • sod. 584mg • calc. 35mg • fiber 3g*

Rustic Tomato Sauce

This is a great basic tomato sauce that is ready in less than an hour.

Makes about 8 cups

- 1 tablespoon extra virgin olive oil**
- 1 onion (8 ounces), peeled and cut into ½-inch pieces**
- 2 carrots (4 ounces), peeled and cut into ½-inch pieces**
- 2 ribs celery, trimmed and cut into ½-inch pieces**
- 4 cloves garlic, peeled**
- 1 teaspoon dried oregano**
- 1 teaspoon dried basil**
- 4 roasted red bell peppers, cut into 1-inch pieces**
- ½ cup dry white wine (such as vermouth)**
- 2 tablespoons tomato paste**
- 3 cans (15 ounces) recipe-ready diced tomatoes with juices**
- ½ teaspoon kosher salt**
- ¼ teaspoon freshly ground black pepper**

In a 3¾-quart saucepan, heat the olive oil over medium heat. Add the onion, carrots, celery, garlic, and basil. Cover loosely and cook until the

vegetables are softened, 6 to 8 minutes. Stir in the roasted red pepper, wine, tomato paste, and tomatoes. Bring to a boil, then reduce heat and simmer for 35 to 40 minutes, loosely covered. Uncover and simmer for 15 to 20 minutes longer to thicken. Turn off heat and let sit 5 minutes.

Strain the solids from the liquids, and return the liquid to the saucepan. Place the solids in the blender jar with ½ cup of the cooking liquid. Cover the blender jar. Select Liquefy and press Pulse 10 times to chop. Use a plastic spatula to scrape the sides of the blender jar. Blend for 30 to 40 seconds, until smooth. Return the puréed tomato mixture to the liquid in the saucepan and reheat gently over medium low heat. Add salt and pepper.

*Nutritional information per ½-cup serving:
Calories 48 (17% from fat) • carb. 8g • pro. 1g • fat 1g
• sat. fat 0g • chol. 0mg • sod. 194mg • calc. 26mg • fiber 2g*

Red Pepper Coulis

This coulis combines the sweet taste of the red pepper with its roasted counterpart to create a flavor-packed, yet healthy sauce, perfect for grilled vegetables, chicken and seafood.

Makes about 2 cups

- 2 pounds sweet red peppers (approximately 5 medium peppers)**
- 5 cloves garlic, unpeeled**
- 1 shallot (about 1 ounce)**
- 1 teaspoon unsalted butter**
- 1 teaspoon extra virgin olive oil**
- 2 tablespoons white wine**
- 1 cup chicken stock or broth**
- ¼ teaspoon fresh lemon juice**
- ¼ teaspoon kosher salt**
- freshly ground pepper to taste**

Preheat oven to 425°F.

Place 2 of the 5 (or half the original amount) peppers on a baking sheet with 5 cloves of garlic. Roast in preheated oven for 15 minutes. Remove the garlic cloves and place in a small heatproof bowl. Return baking tray to oven and continue roasting peppers for an additional 30 minutes, turning peppers a few times to ensure even browning. When peppers are charred evenly, place in the bowl with the garlic and cover tightly with plastic wrap. Let peppers cool and steam to loosen skins, at least 30 minutes. Once cool, peel the skins and remove seeds and discard. Reserve cleaned peppers with peeled garlic cloves (may store the

peppers and garlic together in plastic food storage bag overnight in refrigerator). Chop the remaining peppers into 1-inch pieces.

Place the shallot in the food processor attachment bowl fitted with the chopping blade. Select Liquefy and press Pulse until finely chopped, about 10 pulses. Reserve. Heat butter and olive oil in a 3-quart sauté pan over medium heat. Add chopped shallots, sauté for about 2 minutes, being careful not to pick up any color. Add the chopped raw peppers stir to coat with oil. Reduce heat to low and cover. Allow peppers to sweat over low heat for about 30 minutes until tender, stirring occasionally. Remove lid from pan and increase heat slightly. Add wine and stir until liquid is mostly evaporated, about 2 minutes. Add chicken stock, bring to a simmer and reduce by half, about 5 minutes.

Place the cooked peppers with the reserved roasted peppers (discard garlic or reserve for later use) in the blender jar. Add salt and lemon juice. Select Purée and blend for about 30 seconds. Taste and adjust seasonings as desired.

Nutritional information per ¼-cup serving:
Calories 51 (21% from fat) • carb. 9g • pro. 2g • fat 1g
• sat. fat 0g • chol. 1mg • sod. 103mg • calc. 16mg • fiber 2g

Basic Vinaigrette

This basic vinaigrette is perfect for a crisp green salad.

Makes about 1½ cups; can be doubled or tripled

- 1 clove garlic, peeled**
- 2 tablespoons Dijon-style mustard**
- ½ cup wine vinegar**
- 1 teaspoon kosher salt**
- ½ teaspoon freshly ground pepper**
- ⅔ cup extra virgin olive oil**
- ⅔ cup vegetable oil**

Place the garlic, mustard, vinegar, salt, and pepper in the blender jar. Blend on Liquefy for 10 to 15 seconds. With the machine on, add the oils in a slow, steady stream through pour lid. Continue to blend for an additional 20 to 30 seconds until completely emulsified.

You may change the Basic Vinaigrette by using a different flavor of vinegar, mustard or oil. Try using fresh lemon juice and a little honey for a honey-mustard vinaigrette. Add fresh herbs, sun-dried tomatoes, or pesto for other flavor changes.

Nutritional information per tablespoon:
Calories 109 (97% from fat) • carb. 1g • pro. 0g • fat 12g
• sat. fat 2g • chol. 0mg • sod. 86mg • calc. 1mg • fiber 0g

Raspberry Vinaigrette

Try this pink dressing on a salad of baby spinach. Sprinkle with some crumbled chèvre and dried cranberries to finish.

Makes about 3 cups

- zest of ½ lemon (color only, no bitter white pith)**
- 1 clove garlic, peeled**
- 1 small shallot, peeled, quartered**
- 1½ teaspoons kosher salt**
- 1 teaspoon thyme**
- ½ teaspoon freshly ground pepper**
- ⅔ cup raspberry vinegar**
- ¼ cup fresh lemon juice**
- ½ cup fresh or thawed frozen raspberries**
- 2 tablespoons honey**
- 1 teaspoon xanthan gum* (optional – but helps keep vinaigrette from separating)**
- 1 cup walnut oil**
- ¾ cup canola oil**

Place the zest, garlic, shallot, salt, thyme, and pepper in the blender jar. Pulse using Chop, 5 to 10 times to begin chopping garlic, shallot and zest. Add remaining ingredients in order listed. Blend on Liquefy until completely emulsified and homogenous, about 20 to 30 seconds. Transfer to a resealable storage container. Let stand 30 minutes before using to allow flavors to develop and blend. If not using immediately, refrigerate. Remove from refrigerator 30 minutes before using.

*Can be found in most well-stocked natural foods or health food stores. Xanthan gum is a naturally derived stabilizer that is produced from the fermentation of corn syrup. Often used in baking breads, xanthan gum will help stabilize marinades, vinaigrettes and salad dressings and prevent them from separating. It is an optional ingredient.

Nutritional information per tablespoon:
Calories 75 (93% from fat) • carb. 1g • pro. 0g • fat 8g
• sat. fat 1g • chol. 0mg • sod. 42mg • calc. 2mg • fiber 0g

Creamy Blue Cheese Dressing

Thick and creamy, this dressing is wonderful served over a wedge of chilled iceberg lettuce, and is thick enough that it can be used as a dip for crudités.

Makes 3½ cups

- ¼ **ounce shallot (about ½ shallot), cut into ¼-inch pieces**
- ½ **cup buttermilk**
- 1 **cup sour cream**
- 1 **cup mayonnaise**
- 1 **tablespoon lemon juice**
- 6 **ounces crumbled blue cheese**
- ½ **teaspoon kosher salt**
- freshly ground pepper**

Place shallot pieces in blender jar. Pulse on chop 4 to 5 times. Add remaining ingredients to the blender jar. Blend on Purée until smooth and homogenous, about 15 to 20 seconds. Serve immediately or store in refrigerator for up to one week. If desired, reserve half the crumbled blue cheese and stir in for texture.

Nutritional information per 2 tablespoons:

*Calories 99 (90% from fat) • carb. 1g • pro. 2g • fat 10g
• sat. fat 3g • chol. 12mg • sod. 160mg • calc. 47mg • fiber 0g*

Molasses Rosemary Marinade

This marinade is very good with chicken, duck or pork, as well as shrimp, scallops, salmon (roasted or grilled), tuna or swordfish for the grill. It also makes a nice finishing sauce for sautéed cippolini onions or other sautéed root vegetables.

Makes about 2 cups marinade

- 1 **ounce peeled shallot, cut in ½-inch pieces**
- 1 **clove garlic, peeled and halved**
- ¼ **teaspoon freshly ground black pepper**
- 2 **tablespoons dry rosemary, divided**
- 1 **tablespoon chipotle chile peppers, with adobo sauce**
- ½ **cup maple syrup**
- ½ **cup molasses**
- ½ **cup soy sauce**
- ⅓ **cup canola or grapeseed oil**
- 1 **teaspoon xanthan gum***

Place the shallot, garlic and pepper in the blender jar. Pulse on chop about 3 to 4 times. Add 1 tablespoon of the rosemary and the remaining ingredients in the order listed. Blend on Liquefy for 20 to 30 seconds until

smooth, thick and homogenous. Transfer to a resealable jar or bowl and stir in the remaining tablespoon of rosemary. Let stand for 30 minutes or longer for flavors to blend before using.

Keep marinade properly refrigerated until ready to use. Use to marinate meats and vegetables for grilling or roasting.

*Xanthan gum is a naturally derived stabilizer that is produced from the fermentation of corn syrup. Often used in baking breads, xanthan gum will help stabilize marinades, vinaigrettes and salad dressings and prevent them from separating. It is an optional ingredient.

Nutritional information per 2 tablespoons:

*Calories 94 (42% per serving) • carb. 13g • pro. 1g • fat 5g
• sat. fat 0g • chol. 0mg • sod. 338mg • calc. 89mg • fiber 0g*

SAVORIES

Bacon & Cheddar Pie

Baked in a stoned wheat cracker crust rather than a traditional pastry crust, this quiche-like pie makes a simple supper when served with a salad.

Makes one 9-inch deep-dish pie, about 12 servings

- 5 **ounces stoned wheat crackers, broken into 1-inch pieces**
- ¼ **cup unsalted butter, melted**
- 1 **medium (4 ounces) onion, peeled and cut into ½-inch pieces**
- 1½ **cups light cream**
- 3 **large eggs**
- 1 **teaspoon Worcestershire sauce**
- ½ **teaspoon dry mustard**
- ½ **teaspoon kosher salt**
- ¼ **teaspoon freshly ground pepper**
- 12 **ounces shredded extra-sharp Cheddar cheese**
- 8 **ounces bacon, cooked crispy and crumbled**

Preheat oven to 325°F.

Place a third of the stoned wheat crackers in the blender jar. Pulse using Chop, until finely ground, about 15 pulses. Transfer to a 9-inch deep-dish pie plate. Repeat until all crackers are ground. Stir the melted butter into the cracker crumbs and press the butter-coated cracker crumbs evenly over the bottom and sides of the pie plate. Place in the preheated 325°F oven for 10 minutes. Remove from oven and place on a rack. Let cool slightly.

Place the onion, cream, eggs, Worcestershire sauce, dry mustard, salt, and pepper in the blender jar. Blend using Mix for 15 to 20 seconds.

Place half the shredded cheese in a layer in the bottom of the slightly cooled crumb crust. Top with an even layer of the bacon, and finish with the remaining shredded cheddar cheese. Pour the egg mixture slowly over the top.

Place in the preheated 325°F oven for 60 to 75 minutes, until puffed, browned and custard is set. Let stand 15 minutes before cutting.

Nutritional information per serving:

*Calories 441 (80% from fat) • carb. 10g • pro. 12g • fat 39g
• sat. fat 20g • chol. 141mg • sod. 489mg • calc. 252mg • fiber 1g*

Perfect Popovers

Impress your guests with these deceptively simple popovers that are mixed in a matter of seconds in your Cuisinart® blender.

Makes 18 popovers

- 6 large eggs**
- 2 cups all-purpose flour**
- 2 cups evaporated fat free milk, not reconstituted**
- ½ teaspoon kosher salt**
- 6 tablespoons unsalted butter, melted**

Place the eggs, flour, milk and salt in the blender jar in the order listed; cover blender jar. Blend on Purée for 15 seconds. Scrape the sides of the jar if needed. With the blender running, add the melted butter in a steady stream and blend for an additional 15 to 20 seconds. Let batter rest for 30 to 40 minutes before continuing.

Preheat oven to 425°F. Thoroughly coat eighteen ½-cup popover, custard, or muffin cups with cooking spray or melted butter.

Divide the batter evenly among the prepared pans. Bake in the preheated oven for 20 minutes, then reduce oven temperature to 375°F. Bake for another 20 minutes, until puffy and nicely browned. Use a cake tester to pierce each popover several times and bake for an additional 5 minutes. Remove from oven, loosen from pans with a thin-blade knife and gently lift out. Serve hot.

Nutritional information per popover:

*Calories 126 (37% from fat) • carb. 14g • pro. 6g • fat 5g
• sat. fat 3g • chol. 79mg • sod. 91mg • calc. 93mg • fiber 0g*

Variation

Roasted Garlic Popovers – add 2 tablespoons peeled roasted garlic cloves to the blender with the ingredients listed.

To roast garlic - place peeled garlic cloves in a double thickness of aluminum foil, toss with a tablespoon of olive oil and fold the foil to seal. Place in a preheated 375°F oven for 30 to 40 minutes, until tender and browned. Roasted garlic will keep in a tightly covered container in the refrigerator for about a week.

Welsh Rarebit

Also known as “Welsh Rabbit,” this cheese sauce is traditionally served over toast points or toasted English muffin halves. A slice of tomato can be placed on the toast first for “high tea” and it can also be put under the broiler for a few moments. We have also found that this recipe is delicious served over steamed broccoli or cauliflower, a baked potato, or it could be tossed with cooked pasta shapes to make a macaroni and cheese dish.

Makes 4 cups

- 2¼ cups whole milk or evaporated lowfat milk (not reconstituted)**
- 2 large eggs**
- 3 tablespoons unbleached all-purpose flour**
- 1 tablespoon Dijon-style mustard**
- 1 teaspoon Worcestershire sauce**
- ½ teaspoon kosher salt**
- 1 pound shredded sharp or extra-sharp Cheddar cheese paprika (for dusting on top)**

Heat the milk in a saucepan until simmering (just bubbles are just breaking at the surface) – this may also be done in a microwave.

Place the eggs, flour, mustard, Worcestershire sauce, and salt in the blender jar. Blend on Mix for 15 to 20 seconds. Scrape the sides of the blender jar. Add the shredded cheese and blend on Purée. With the blender running, add the hot milk in a slow steady stream through the opening in the lid. Blend on Purée until smooth and homogenous, about 30 to 40 seconds.

Pour the mixture into a medium (2¾-quart) saucepan. Place over medium heat, and cook, stirring constantly with a whisk until creamy, smooth and thickened, about 15 to 20 minutes.

Serve over toast points or toasted English muffin halves. Dust with paprika before serving.

Nutritional information per ¼-cup serving:

*Calories 156 (67% from fat) • carb. 3g • pro. 10g • fat 12g
• sat. fat 7g • chol. 74mg • sod. 272mg • calc. 250mg • fiber 0g*

Savory Crêpes

This is a great all-purpose crêpe, ready for your favorite fillings

Makes 5 cups crêpe batter, about 20 crêpes

- 6** eggs
- 1½** cups unbleached, all-purpose flour
- 1** teaspoon kosher salt
- 2** cups milk
- ½** cup unsalted butter, melted
- 1** tablespoon fresh chives, finely minced

Place eggs, flour, salt and milk in the blender jar. Blend on Liquefy for about 30 seconds. Scrape the blender jar well and blend again for another 30 seconds. With the blender running, add the melted butter and continue to blend for 30 seconds. Stir in the chives.

Allow batter to rest for at least ½ hour before using. Crêpe batter will keep for up to 3 days.

To make the crêpes, preheat an 8- or 10-inch nonstick skillet or crêpe pan over medium heat and coat lightly with cooking spray. Tilt the pan and pour in just enough batter to cover the entire surface of the skillet (about 2 to 4 tablespoons). Cook until the edges just start to brown, then turn the crêpe over and cook on the other side for about 30 seconds. Crêpes can be made and stacked with a sheet of waxed paper or plastic wrap between each one. Wrap stack in plastic wrap and refrigerate for up to 1 week until ready to use.

For Sweet Crêpes – omit the chopped chives and add ¼ cup of granulated sugar and 2 teaspoons pure vanilla extract to the above recipe.

Nutritional information per crêpe:

*Calories 112 (56% from fat) • carb. 8g • pro. 4g • fat 7g
• sat. fat 4g • chol. 79mg • sod. 98mg • calc. 39mg • fiber 0g*

Pumpkin Pie with Graham Pecan Crust

The traditional holiday favorite is made with a cookie crumb crust for a crunchy change.

Makes 8 to 12 servings

Crust

- ½** cup pecan halves
- 6** graham cracker squares, broken into 1-inch pieces
- 3** tablespoons granulated sugar
- ¼** cup unsalted butter, melted

Pumpkin Filling

- 2** large eggs
- ½** cup brown sugar
- 1** can (12 ounces) evaporated fat free milk
- 1** can (15-16 ounces, 1½ cups) solid pack pumpkin (not pie filling)
- 1** tablespoon cornstarch
- ¼** cup maple syrup
- 1** tablespoon vanilla extract
- 1** teaspoon cinnamon
- ½** teaspoon ground ginger
- ½** teaspoon ground allspice
- ⅛** teaspoon freshly grated nutmeg

Preheat the oven to 375°F.

Place the pecans in the blender jar; cover the blender jar. Pulse on Chop 8 to 10 times to chop finely. Remove and reserve. Place graham cracker pieces in the blender jar; cover the blender jar. Pulse on Chop 5 times to break up the cookies, then blend on Chop for 10 seconds to pulverize; add the reserved chopped nuts and granulated sugar. Blend on Mix until nuts are evenly and finely ground. Transfer to a 9-inch deep-dish pie plate. Add the melted butter and stir to combine. Press the cookie/nut mixture evenly onto the sides and bottom of the pie plate. Bake in the preheated 375°F oven for 5 minutes. Remove and let cool on a rack while continuing. Lower the oven temperature to 350°F.

Place the eggs and remaining ingredients in the blender jar in the order listed; cover the blender jar. Blend on Mix until smooth, about 10 to 15 seconds. Pour the pumpkin mixture into the prepared pecan graham crust. Bake in the preheated 350°F oven for 55 to 60 minutes. Center of the pie may appear slightly jiggly – it will continue to set as the pie cools. Place the pie on a rack and cool completely before serving. Refrigerate after completely cool.

Nutritional analysis per serving (based on 12 servings):

*Calories 191 (37% from fat) carb 27g • pro. 4g • fat 8g
• sat. fat 3g • chol. 46mg • sod. 73mg • calc. 117mg • fiber 2g*

Coconut Cream Pie

A cross between a custard pie and a cheesecake, this pie is delicious and simple to prepare. Serve with a dollop of freshly whipped cream for pure indulgence.

Makes 8 to 12 servings

- 4** ounces vanilla wafers or ginger snaps, broken into quarters
- 4** tablespoons unsalted butter, melted

- 2½ cups shredded sweetened coconut, divided**
- 3 large eggs**
- ¾ cup granulated sugar**
- 12 ounces lowfat cream cheese, cut into 1-inch (or smaller) pieces**
- 1 tablespoon fresh lemon juice**
- 1 teaspoon pure vanilla extract**
- ½ teaspoon coconut extract**

Arrange rack in lower third of oven. Preheat oven to 350°F.

Place cookies in blender jar. Pulse 10 times on Chop. Scrape the jar. Using Mix, blend for 20 to 30 seconds until pulverized. Transfer to a small bowl. Add the melted butter and ¾ cup of the shredded coconut; stir to combine thoroughly. Press evenly into the bottom and sides of a 9-inch deep-dish pie plate. Place in oven and bake for 10 minutes. Let cool on a rack 5 minutes before continuing.

Place eggs, sugar, cream cheese, lemon juice, and extracts in the blender jar. Blend on Purée for 15 seconds; scrape blender jar. Blend again for 15 seconds. Add the remaining coconut and pulse on Mix until combine, 6 to 8 pulses. Pour into the prepared pie shell and place in the preheated 350°F oven. Bake for about 30 to 40 minutes, until slightly puffed and set at edges – may be slightly jiggy in the center. Cool on a rack completely. Refrigerate pie for at least 2 hours before serving.

Nutritional information per serving (based on 12 servings):
Calories 269 (51% from fat) • carb. 28g • pro. 6g • fat 15g
• sat. fat 10g • chol. 74mg • sod. 260mg • calc. 50mg • fiber 1g

Chocolate Pots de Crèmes

Totally decadent and indulgent – a chocolate lover’s delight!
 Everyone needs a treat now and then.

Makes 8 servings

- 3 cups heavy cream**
- 8 ounces semisweet chocolate morsels or chocolate chunks (½-inch pieces)**
- 2 tablespoons granulated sugar**
- 1 teaspoon instant espresso powder**
- 7 large egg yolks, lightly beaten**
- 2 teaspoons pure vanilla extract**

Have ready eight 5-ounce ramekins or pots de crème dishes. Place in a 13x9x3-inch pan. Bring 4 cups of water to a boil; keep hot and reserve. Arrange rack in center of oven. Preheat oven to 325°F.

Place heavy cream in a saucepan and bring to a simmer over medium heat – do not boil.

Place the chocolate morsels/chunks, granulated sugar, and espresso powder in the blender jar. Pulse on Chop 10 to 15 times to chop the chocolate somewhat finely. Add the egg yolks and blend for 20 seconds on Mix. With the blender running on Purée, add the hot heavy cream through the pour lid in a slow steady stream and blend until chocolate is completely melted, about 45 seconds. Spoon off foam and discard (may also put in a fat separator and pour off liquid until just foam remains). Stir in vanilla.

Pour equal amounts of the chocolate mixture into each of the ramekins. Place pan in oven and add hot water to reach halfway up the sides of the ramekins. Bake in preheated 325°F oven for 55 to 60 minutes. Edges will be set, centers may still be slightly jiggy.

Transfer ramekins to a rack to cool completely, uncovered, about 1 hour. (They will set as they cool.) Serve warm, or chill, covered, until cold, at least 3 hours. Chocolate Pots de Crèmes may be garnished with freshly whipped cream and/or chocolate curls.

Nutritional information per serving:
Calories 510 (80% from fat) • carb. 21g • pro. 4g • fat 46g
• sat. fat 26g • chol. 308mg • sod. 40mg • calc. 79mg • fiber 4g

Apple Bread Pudding

For a warm dessert, bread pudding can be mixed and assembled ahead of time and baked while dinner is being served. Top warm Apple Bread Pudding with sweetened whipped cream or vanilla ice cream.

Makes 8 to 12 servings

- 3 tablespoons unsalted butter**
- 8 ounces Granny Smith apples, sliced thinly**
- 1 teaspoon lemon juice**
- 6 cups firm bread cubes ***
- 6 large eggs**
- 1 can (12 ounces) evaporated lowfat milk (not reconstituted)**
- ½ cup sugar**
- ½ tablespoon vanilla extract**
- 1½ teaspoons cinnamon**
- ¾ cup heavy cream**

Butter a 2-quart shallow baking dish (9 x 9 inches square or equivalent) with 1 tablespoon unsalted butter and place in a larger shallow baking pan. Toss the apple slices with the lemon juice. Melt the remaining 2

tablespoons of butter and toss in a large mixing bowl with bread cubes and apple slices.

Place the eggs, evaporated milk, sugar, vanilla, cinnamon, and heavy cream in the blender jar. Blend on Purée for 20 seconds. Pour the mixture over the bread cubes. Pour mixture into prepared pan. Let the mixture stand for 45 minutes, or cover and refrigerate up to 12 hours (if refrigerated, let come to room temperature for 30 minutes before proceeding).

Ten minutes before baking, preheat oven to 325° F. Place the baking pans in the oven and carefully pour hot water into the larger, outer pan until the water comes up the sides of the inner dish by 1 inch. Bake for 60 to 70 minutes, bread pudding will be puffed and custard will be set. Remove from oven and allow the bread pudding to rest for 20 to 30 minutes on a rack before serving. Serve with sweetened whipped cream.

*Bread pudding is best made from day-old bread. Use a high quality bread with firm crumb. Suggested breads: challah, cinnamon swirl or cinnamon raisin, or best quality sandwich bread.

Nutritional information per serving based on 12 servings:
Calories 294 (26% from fat) • carb. 48g • pro. 7g • fat 9g
• sat. fat 4g • chol. 128mg • sod. 156mg • calc. 125mg • fiber 1g

©2006 Cuisinart

Cuisinart® is a registered trademark of Cuisinart
Any other trademarks or service marks referred to herein are
the trademarks or service marks of their respective owners.

Version no.: SB5600 IB-6087
Size : 216MM(W) X 178MM(H)
Material: COVER:157GSM MATT ARTPAPER INSIDE:120GSM GLOSS ARTPAPER
Coating: VARNISHING
Color (Front): COVER:4C(CMYK)+1C(BK) (Back): INSIDE:1C(BK)+1C(BK)
Date: JAN-23-2006 Co-ordinator: Astor
Hugo Description : IB-6087(0,0) OPERATOR:FEN
Hugo code: TKL0017IB-1-1

